

# RESIDUAL CURRENT DEVICES

# Electrical installation solutions for buildings – Technical details

## RCDs

### Index

Functions and classification criteria for RCDs	2
Limitation of specific let-through energy $I^2t$	6
Peak current $I_p$	17
SOC - Selected Optimized Coordination	28
Coordination tables:	
residual current protection selectivity	29
Power loss, derating and performance in altitude	34
Tripping characteristic	41
Emergency stop using DDA 200 AE series	42
Terminal capacity for F200, DS201 and DS203NC	43
Terminal capacity for DDA200	44
Unwanted tripping - AP-R solution (high immunity)	47
Unwanted tripping - F2C-ARH solution	49
Type B RCDs	57
Series connection of RCDs	60
Use of 4P RCCBs in 3-phase system without neutral pole	66
Operating voltage of test button	67
RD2 residual current relays	72
RD3 residual current relays	73
ELR front panel residual current relays	76
Toroidal transformers	77



## RCDs technical details

### Functions and classification criteria for RCDs

#### Overview of the RCCB types

The variety of residual current protective devices (RCDs) has increased continuously over the last few decades following technological development and the massive introduction of electronics in all areas of application.

In accordance with the possibility of recognizing the most varied forms of residual current and the relatively demanding device testing, the spectrum of RCD types today ranges from protecting pure AC consumers to high-frequency consumers. The level of protection is shifting more and more from the AC and A types to the F and B types.

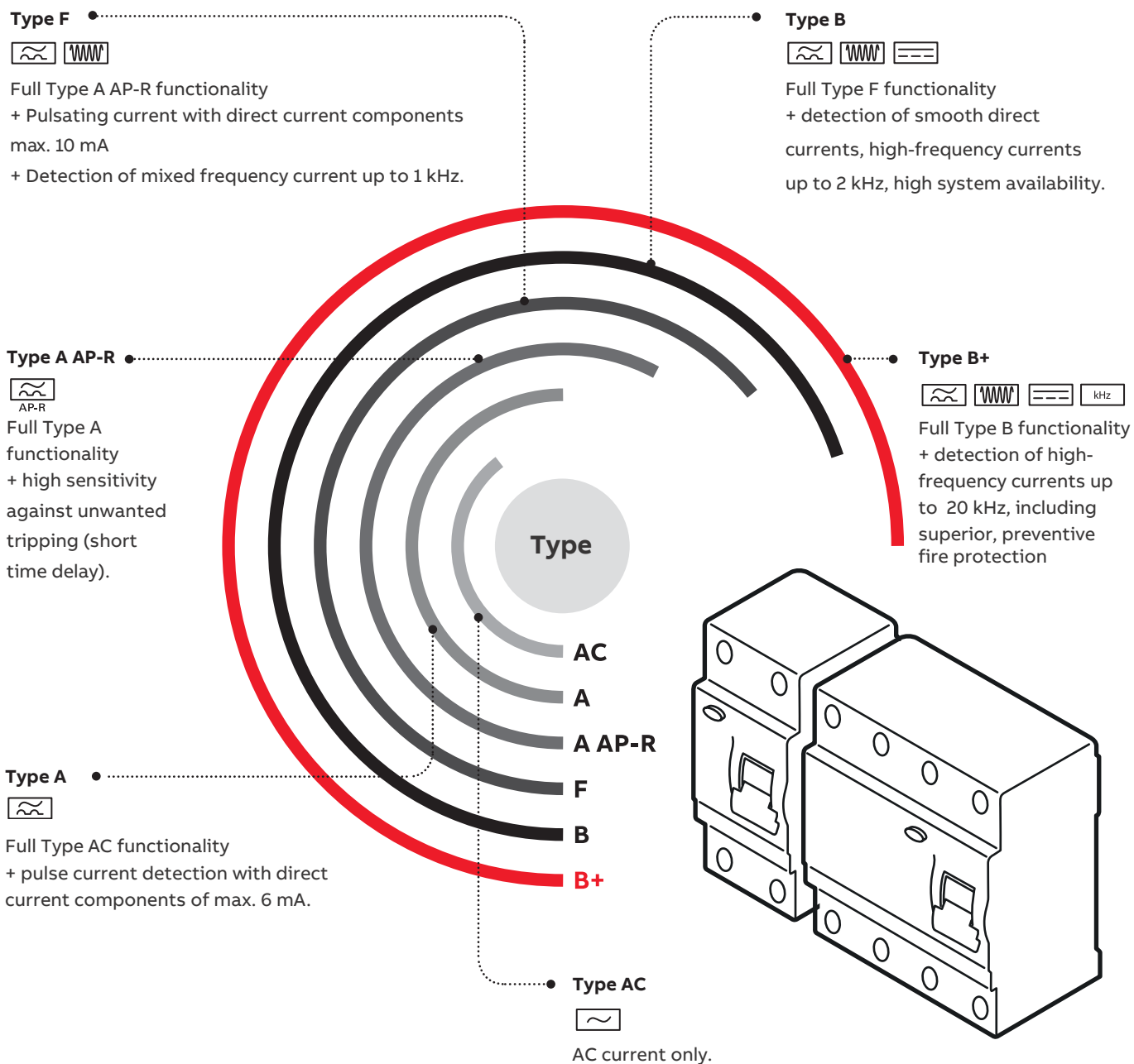

## RCDs technical details

### Functions and classification criteria for RCDs

#### Functions and classification criteria for RCDs

A residual current operated circuit-breaker is an amperometric protection device which is tripped when the system leaks a significant current to earth.

This device continuously calculates the vector sum of the single-phase or three-phase system line currents and while the sum is equal to zero allows electricity to be supplied. This supply is rapidly interrupted if the sum exceeds a value preset according to the sensitivity of the device.

Residual current operated circuit-breakers can be classed according to four parameters:

- type of construction
- detectable wave form
- tripping sensitivity
- tripping time.

Depending on the type of construction, RCDs may be classed as:

- RCBOs (magnetothermic with overcurrent protection)
- RCCBs (without overcurrent protection releaser incorporated)
- RCD blocks.

RCBOs combine, in a single device, the residual current function and the overcurrent protection function typical of MCBs. RCBOs are tripped by both current leakage to earth and overloads and short-circuits and they are self-protecting up to a maximum short-circuit current value indicated on the label.

RCCBs are only sensitive to current leakage to earth. They must be used in series with an MCB or fuse which protects them from the potentially damaging thermal and dynamic stresses of any overcurrents.

These devices are used in systems already equipped with MCBs which preferably limit the specific energy passing through, also acting as the main disconnecting switches upstream of any derived MCBs (e.g.: domestic consumer unit). RCD blocks are residual current devices suitable for assembly with a standard MCB. IEC/EN 61009 app. G only allows assembly of RCBOs once on site, that is to say outside the factory, using adaptable RCD blocks and the appropriate MCBs. Any subsequent attempts to separate them must leave permanent visible damage. The residual current operated circuit-breaker obtained in this way maintains both the electrical characteristics of the MCB and those of the RCD block.

According to the wave form of the earth leakage currents they are sensitive to, the RCDs may be classed as:

- AC type (for alternating current only)
- A type (for alternating and/or pulsating current with DC components)
- F type (for alternating and/or pulsating current with DC components with detection of high frequency currents up to 1 kHz.)
- B type (for alternating and/or pulsating current with DC components and continuous fault current).

AC type RCDs are suitable for all systems where users have sinusoidal earth current.

They are not sensitive to impulsive leakage currents up to a peak of 250 A (8/20 wave form) such as those which may occur due to overlapping voltage impulses on the mains (e.g.: insertion of fluorescent bulbs, X-ray equipment, data processing systems and SCR controls).

A type RCDs are not sensitive to impulsive currents up to a peak of 250 A (8/20 wave form).

They are particularly suitable for protecting systems in which the user equipment has electronic devices for rectifying the current or phase cutting adjustment of a physical quantity (speed temperature, light intensity, etc.) supplied directly by the mains without the insertion of transformers and insulated in class I (class II is, by definition, free of faults to earth). These devices may generate a pulsating fault current with DC components which the A type RCD can recognise.

F type RCDs can detect sinusoidal AC currents as well as pulsating DC currents. In addition to this, they are also tested according to IEC/EN 62423 which foresees the application of a simulated multi-frequency residual current with appropriate coefficient associated to the each level of frequency up to 1kHz.

The intervention characteristic has a short-time delayed which prevents unwanted tripping in case pulsed leakage currents of up to ten milliseconds occur at activation of filters.

The RCDs Type F have a surge current withstand capacity of more than 3kA and can accept superimposed smooth DC residual currents of up to 10mA without affecting their standard functionality.

Main area of use are the circuits of single phase inverters regulating the speed of motors by supplying a variable frequency, from 10 to 1000 Hz.

## RCDs technical details

### Functions and classification criteria for RCDs

B type RCDs are recommended for use with drives and inverters for supplying motors for pumps, lifts, textile machines, machine tools, etc., since they recognise a continuous fault current with a low level ripple. Type AC, A and B RCDs comply with IEC/EN 61008/61009, moreover type B is covered by IEC 62423 Ed. 1 and by IEC/EN 60755 for residual current operated protective devices. According to tripping sensitivity ( $I_{\Delta n}$  value), RCDs may be divided into the following categories:

- low-sensitivity ( $I_{\Delta n} > 0.03$  A), not suitable for protection against direct contacts; co-ordinated with the earth system according to the formula  $I_{\Delta n} < 50/R$ , to provide protection against indirect contacts;
- high-sensitivity ( $I_{\Delta n}$ : 0.01...0.03 A), or “physiologically sensitivity” for protection against indirect contacts, with simultaneous additional protection against direct contacts.
- against fire (up to 500 mA) according to IEC/EN 60364.

### Residual current sensitivity and environment

#### Household and special environments



$I_{\Delta n}$   
 $\leq 30$  mA

#### High-sensitivity or physiologically sensitive RCDs

IEC/EN 60364 makes the use of these devices mandatory in all bathrooms, showers and private and public swimming pools and environments in which plugs and sockets may be installed without insulating or low safety voltage transformers.

#### Laboratories, service industry and small industry



$I_{\Delta n}$   
from 30 mA  
to 500 mA

#### Low-sensitivity RCDs

#### Large service industry and industrial complex



$I_{\Delta n}$   
from 500 mA  
to 1000 mA

According to their tripping time, RCDs can be classed as:

- instantaneous (or rapid or general)
- type S selective (or - incorrectly - delayed).

Selective RCDs (RCBOs - RCCBs or RCD-blocks) have a delayed tripping action and are installed upstream of other rapid residual current operated circuit-breakers to guarantee selectivity and limit the power out only to the portion of the system affected by a fault.

## RCDs technical details

### Functions and classification criteria for RCDs

The tripping time is not adjustable. It is set according to a predetermined time – current characteristic with an intrinsic delay for small currents, tending to disappear as the current grows. IEC/EN 61008 and 61009 establish the tripping times relative to the type of RCD and the  $I_{\Delta n}$ .

	$I_n$ [A]	$I_{\Delta}$ [A]	Tripping times (s)xcurrents			
			$1 \times I_{\Delta}$	$2 \times I_{\Delta}$	$5 \times I_{\Delta}$	500A
General (instantaneous)	Any	Any	0.3	0.15	0.04	0.04
S (selective)	Any	>0.030	0.13-0.5	0.06-0.2	0.05-0.15	0.04-0.15

The indicated breaking times refer to the alternating residual current suddenly applied to any RCDs of types AC, A, F, or B. ABB AP-R RCDs of types F and B trip within the standard limit for general RCDs (instantaneous), but with an added short time delay of 10 ms to provide immunity against unwanted tripping.

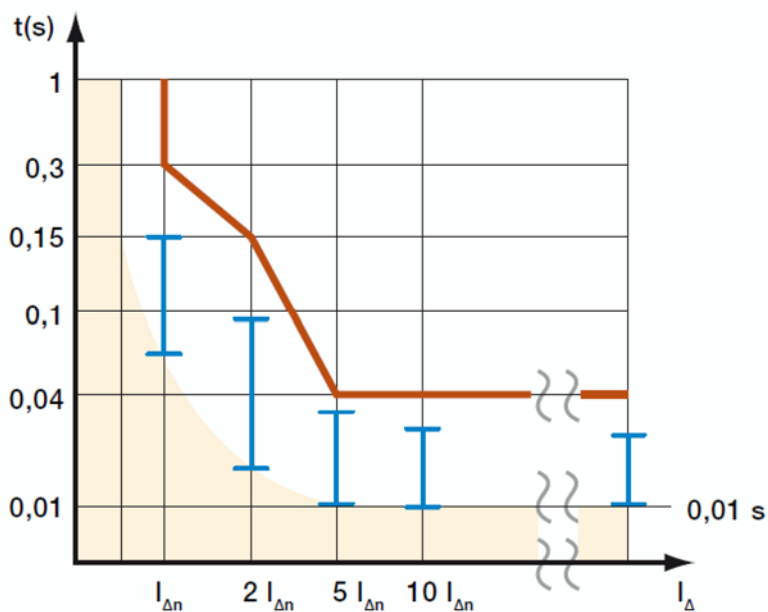

#### Review description on the side as follow:

- No tripping for short duration residual current
- Maximum break time allowed by standards
- Tripping time range for APR device

- Non-intervention brief duration current
- Maximum intervention time allowed by regulations
- Intervention range for APR devices

## RCDs technical details

### Limitation of specific let-through energy $I^2t$

#### $I^2t$ diagrams - Specific let-through energy value $I^2t$

The  $I^2t$  curves give the values of the specific let-through energy expressed in  $A^2s$  (A=amps; s=seconds) in relation to the perspective short-circuit current ( $I_{rms}$ ) in kA.

#### DS 200-DS 200 M, characteristics B and C 230/400 V let-through energy

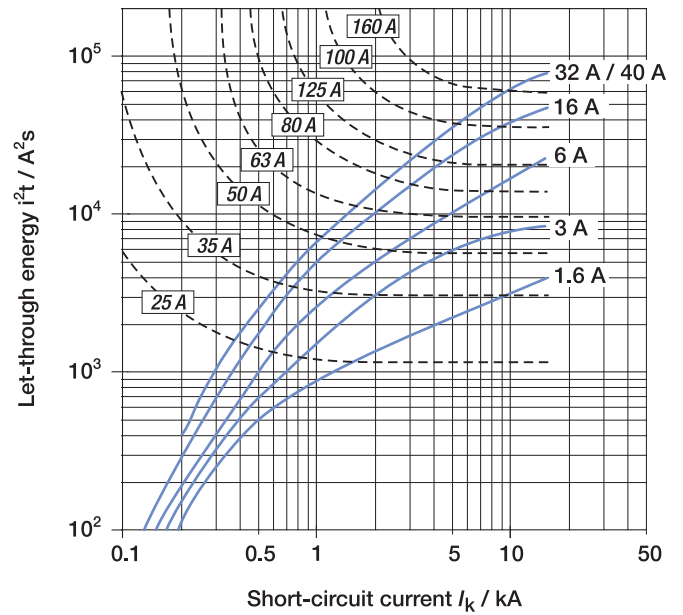
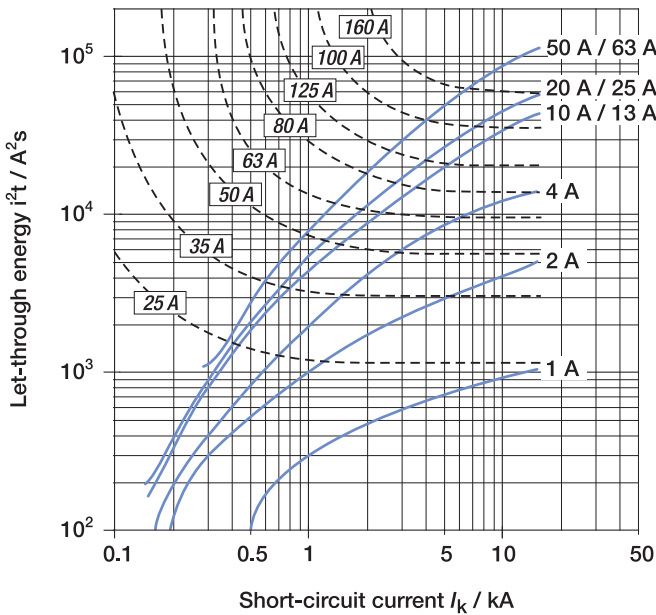

#### DS201 L - DS201 - DS201 T - DS201 M characteristics B and C 230 V let-through energy

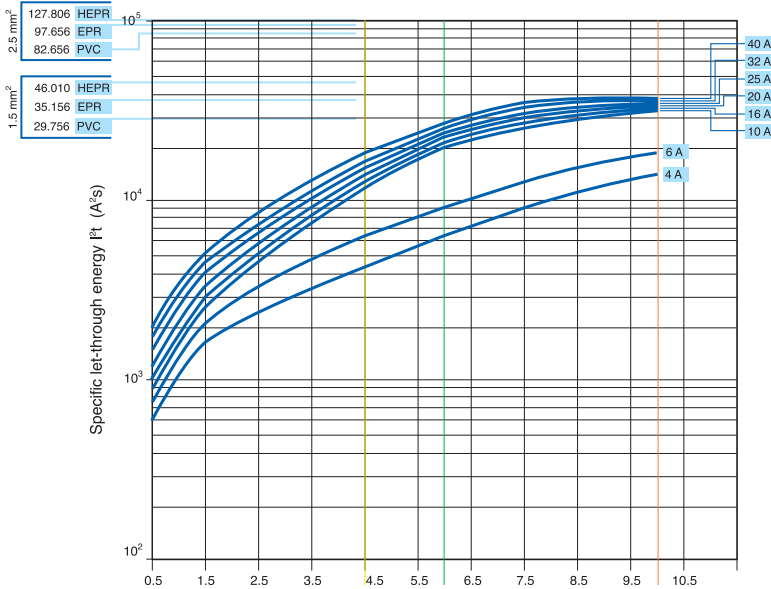

#### DS202CR - DS202CR M characteristics B and C 230 V let-through energy

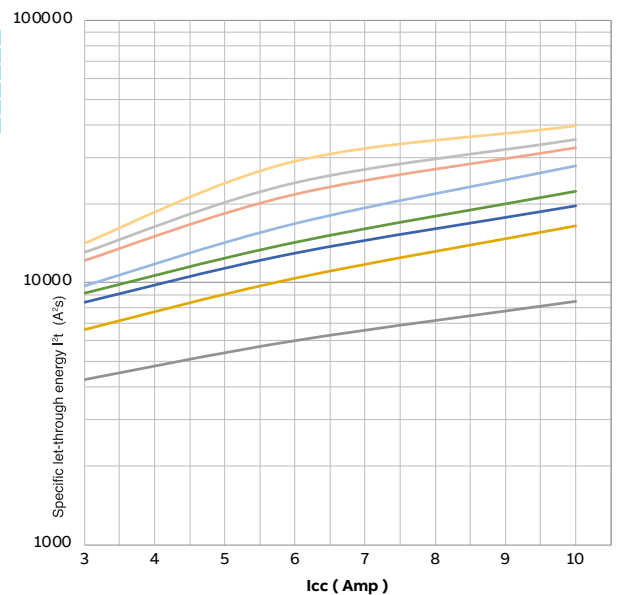

- 40A
- 32A
- 25A
- 20A
- 15A % 16A
- 13A
- 10A
- 6A

## RCDs technical details

### Limitation of specific let-through energy $I^2t$

#### Specific let-through energy $I^2t$ DS201L - Characteristic C

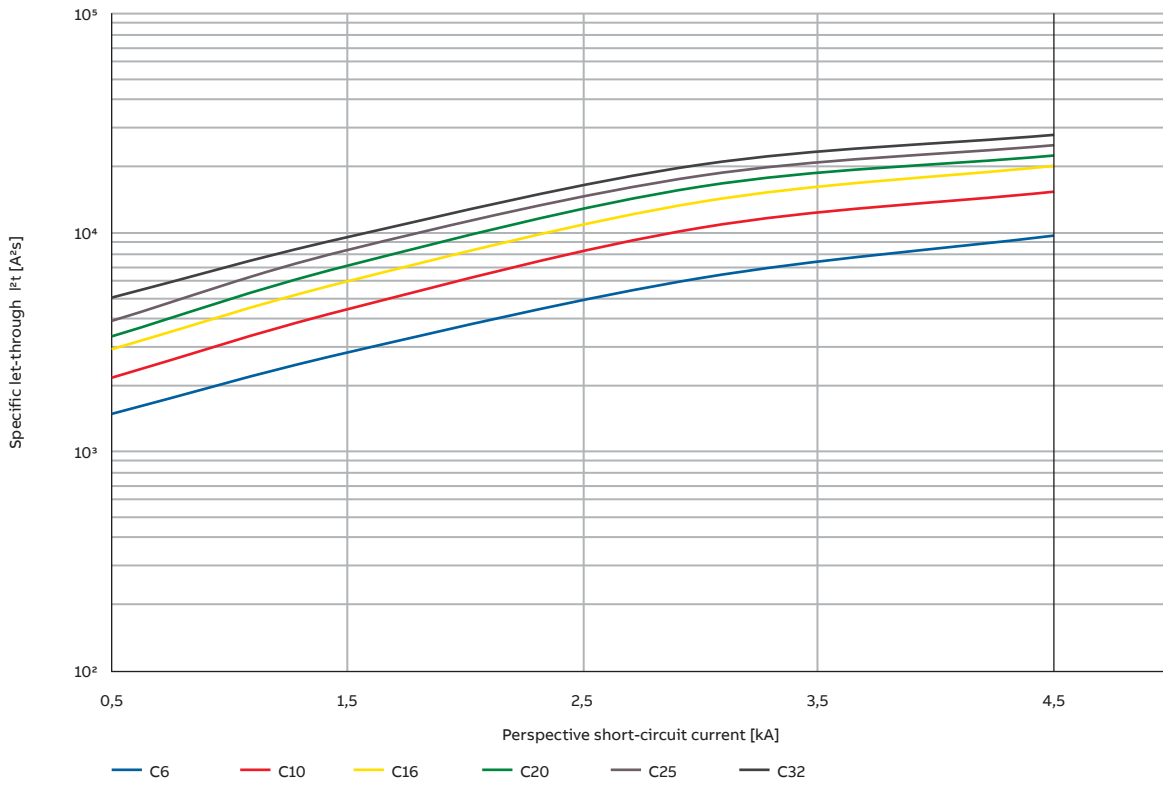

#### Specific let-through energy $I^2t$ DS201 - Characteristic B

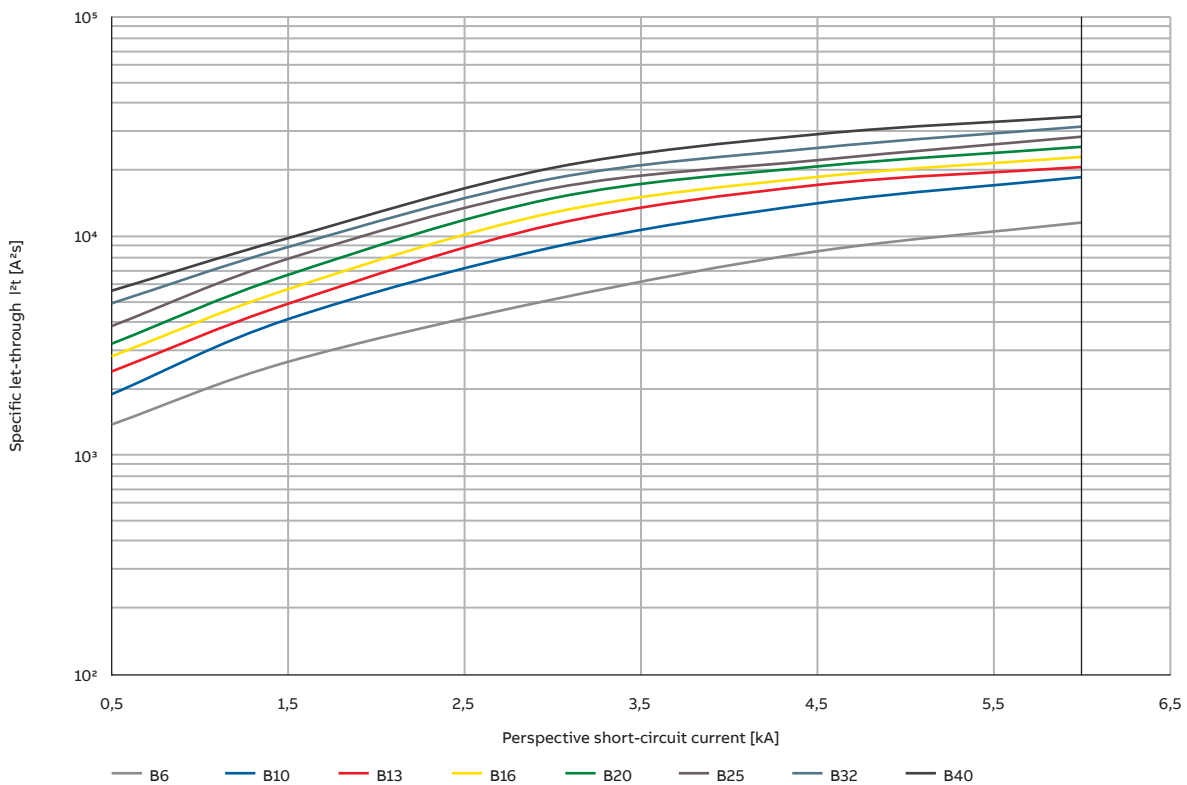

## RCDs technical details

### Limitation of specific let-through energy $I^2t$

#### Specific let-through energy $I^2t$ DS201 - Characteristic C

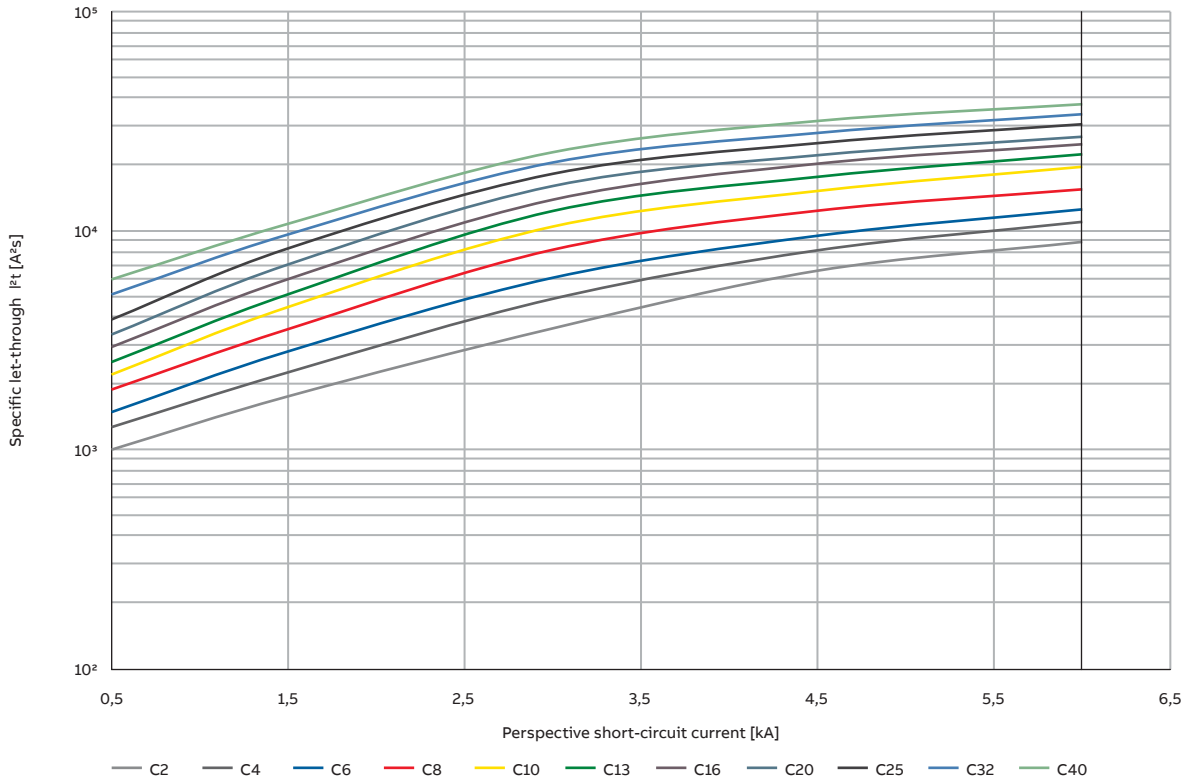

#### Specific let-through energy $I^2t$ DS201 - Characteristic K

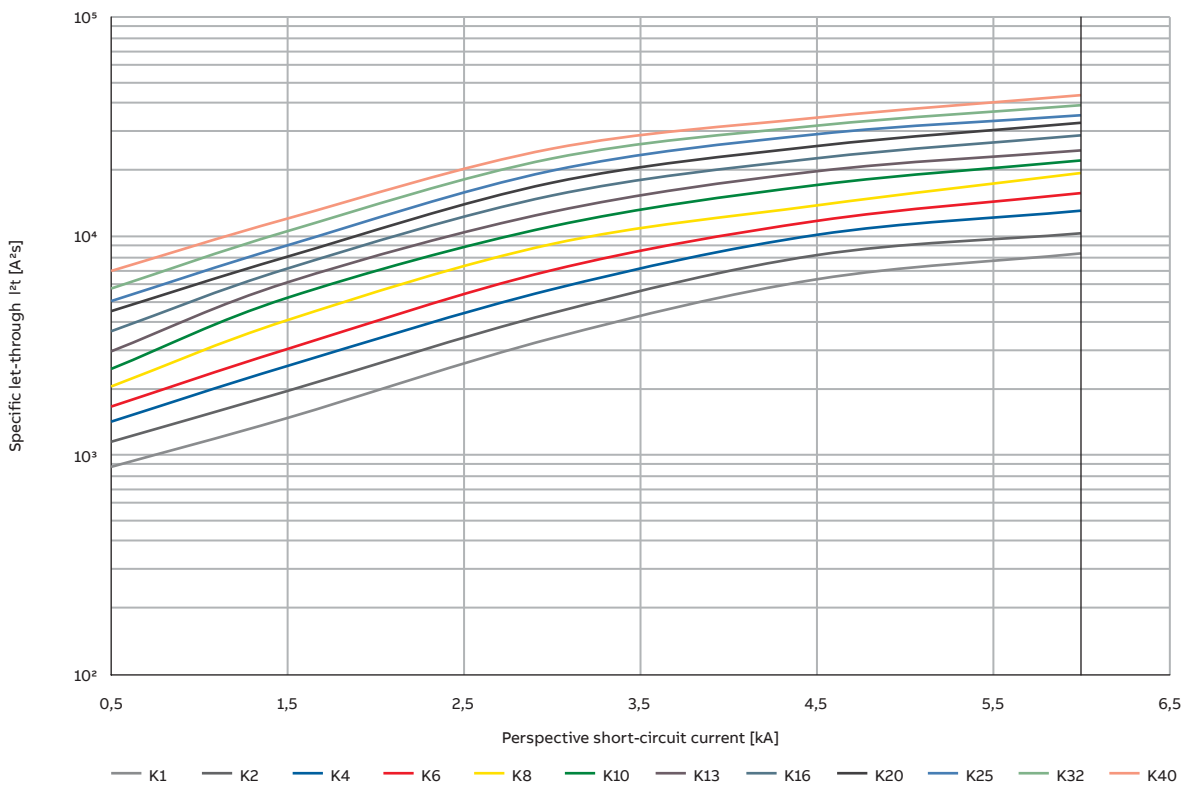

## RCDs technical details

### Limitation of specific let-through energy $I^2t$

#### Specific let-through energy $I^2t$ DS201M - Characteristic B

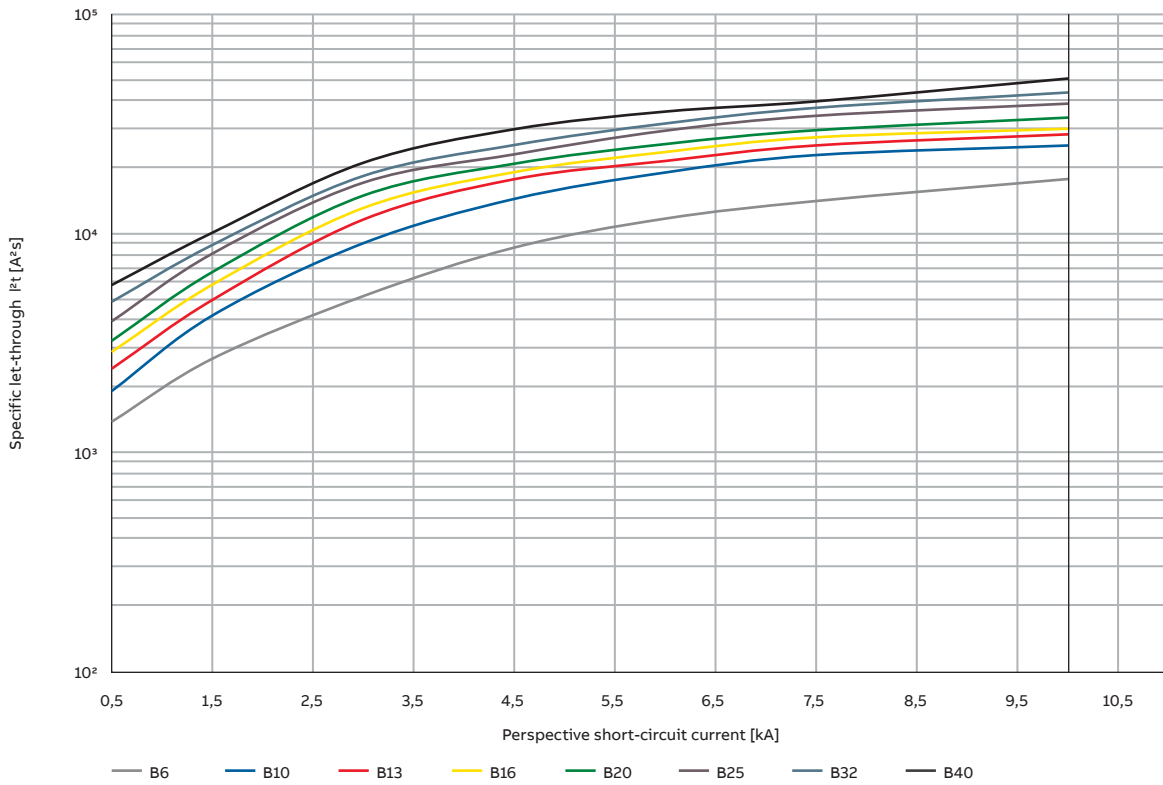

#### Specific let-through energy $I^2t$ DS201M - Characteristic C

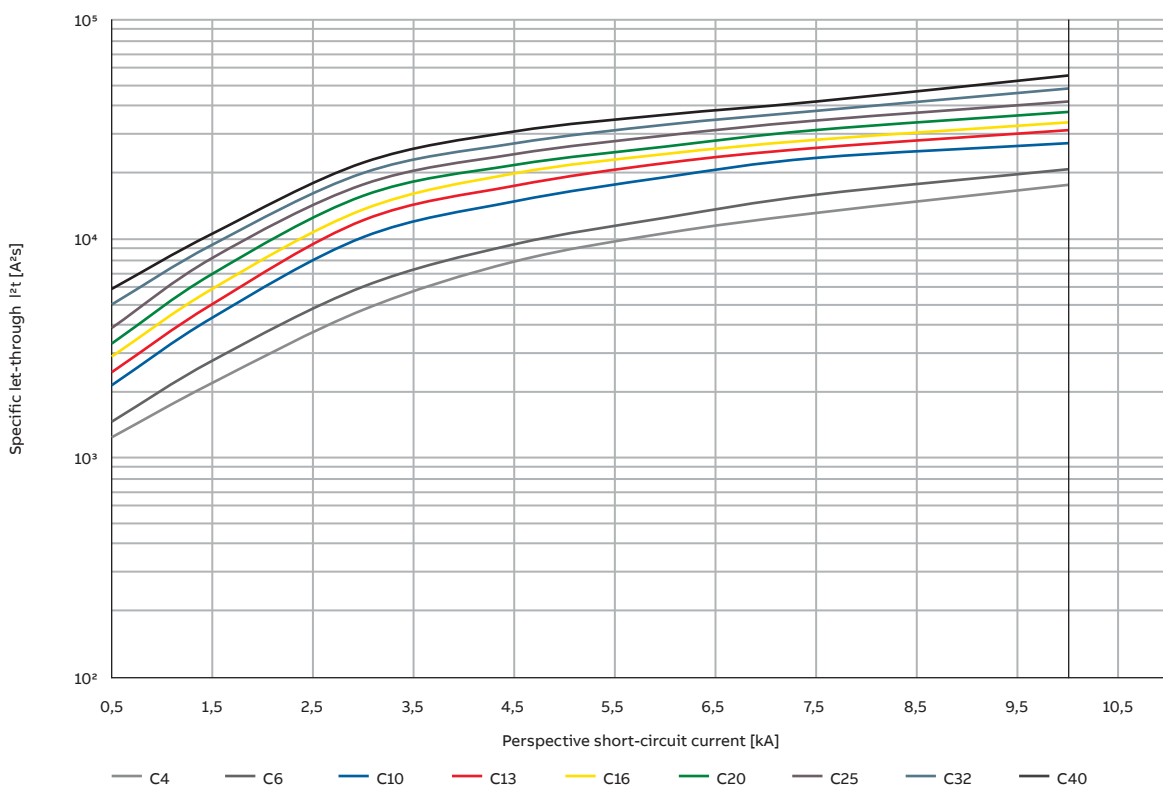

## RCDs technical details

### Limitation of specific let-through energy $I^2t$

#### Specific let-through energy $I^2t$ DS201M - Characteristic K

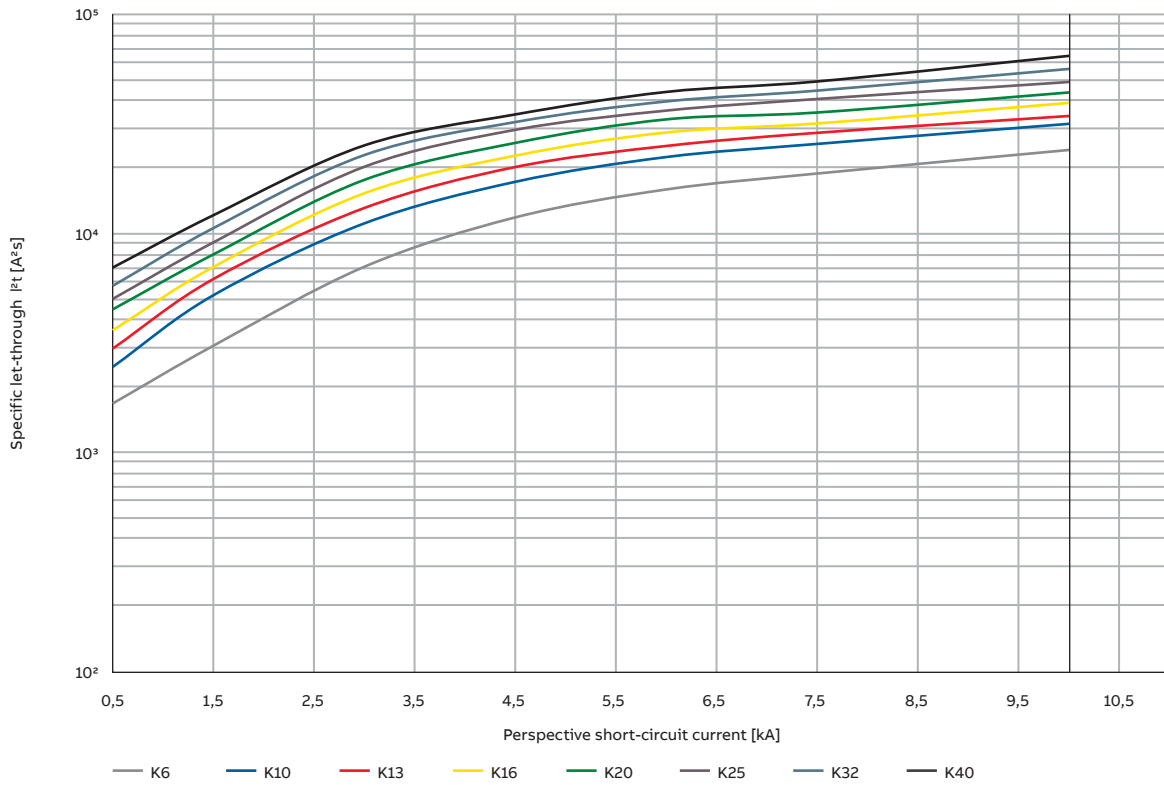

## RCBO DS301C

### Technical data

#### Specific let-through energy $I^2t$ DS301C—Characteristic C

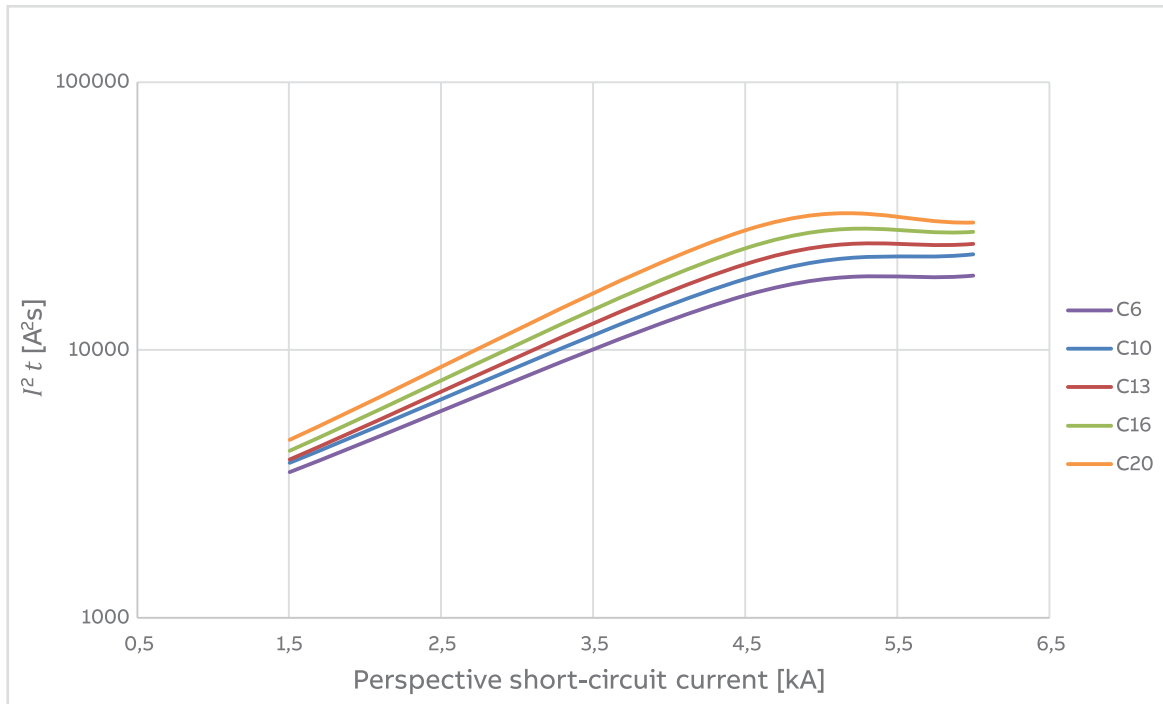

#### Specific let-through energy $I^2t$ DS301C—Characteristic B

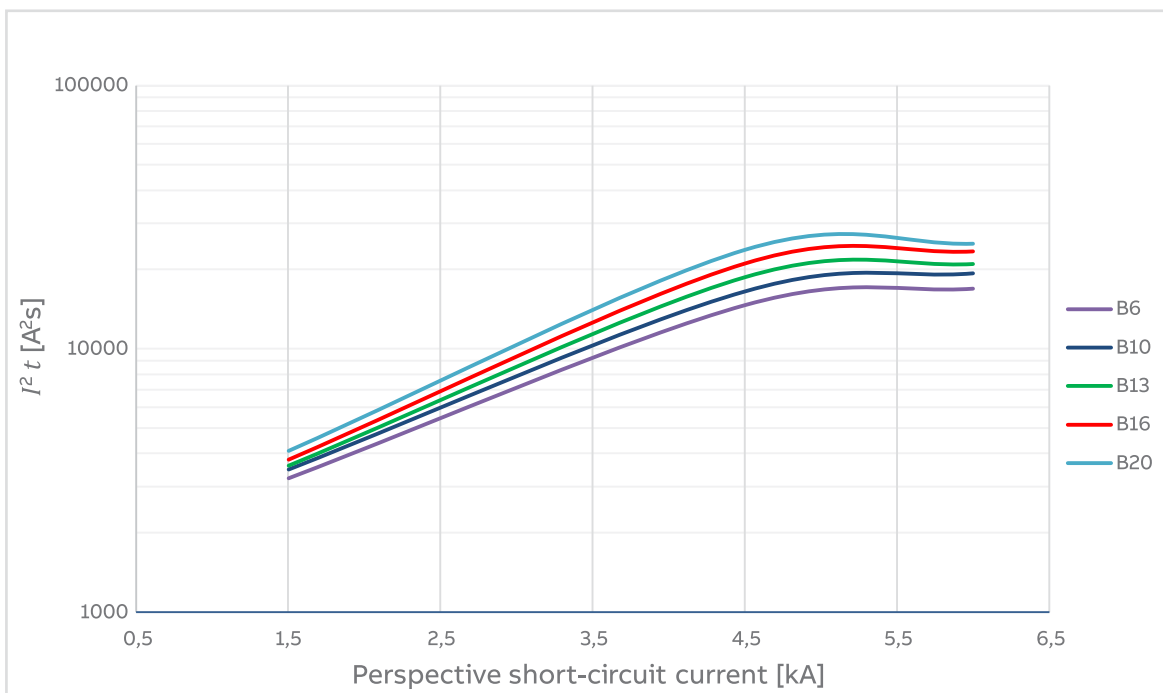

## RCDs technical details

### Limitation of specific let-through energy $I^2t$

#### DS203NC L, characteristic B

400 V let-through energy

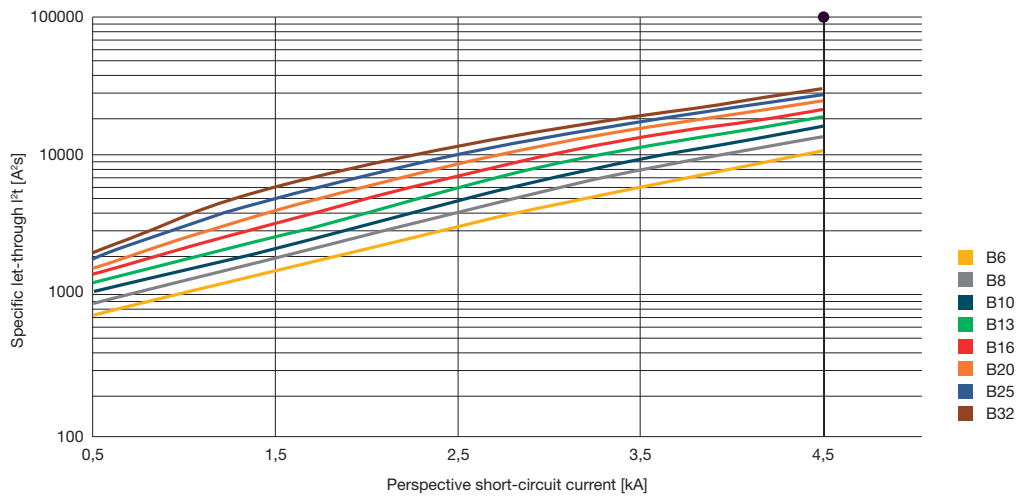

#### DS203NC, characteristic B

400 V let-through energy

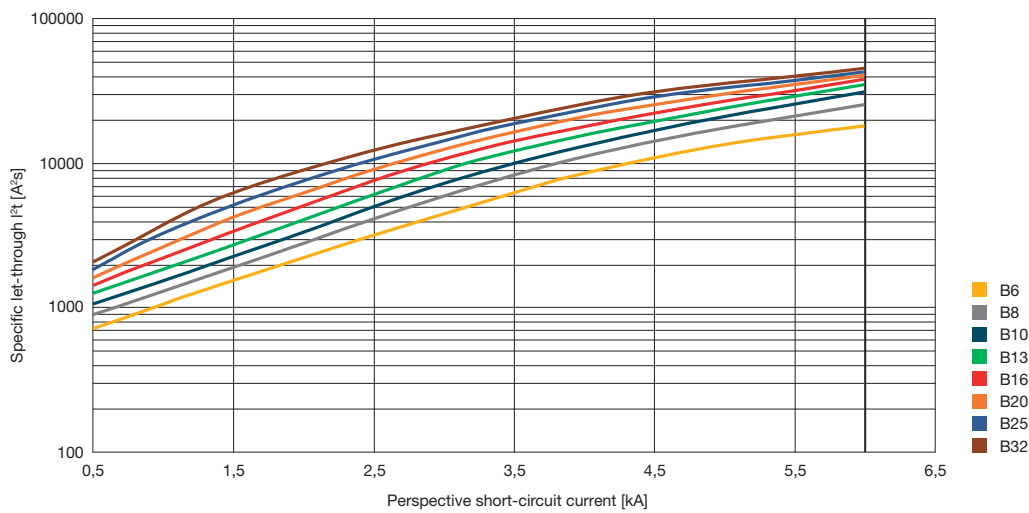

## RCDs technical details

### Limitation of specific let-through energy $I^2t$

#### DS203NC L, characteristic C

400 V let-through energy

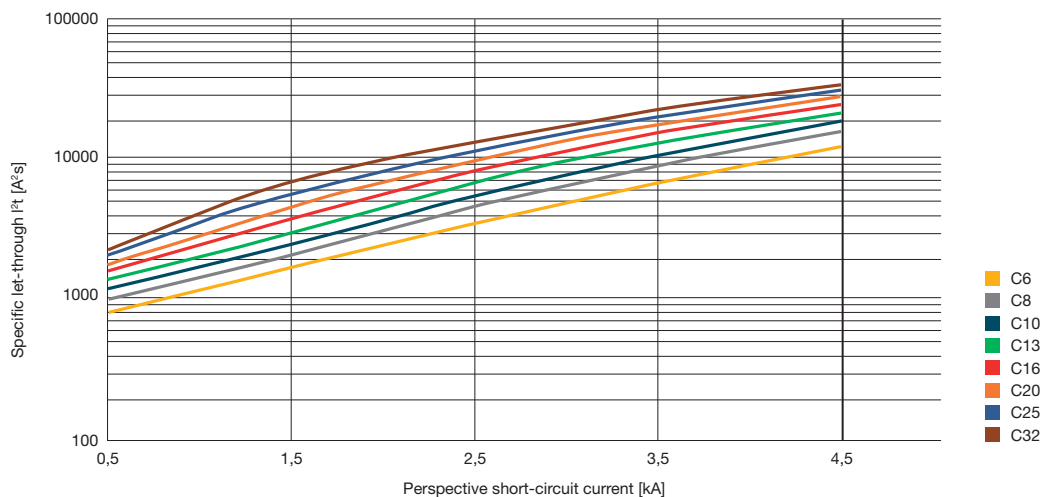

#### DS203NC, characteristic C

400 V let-through energy

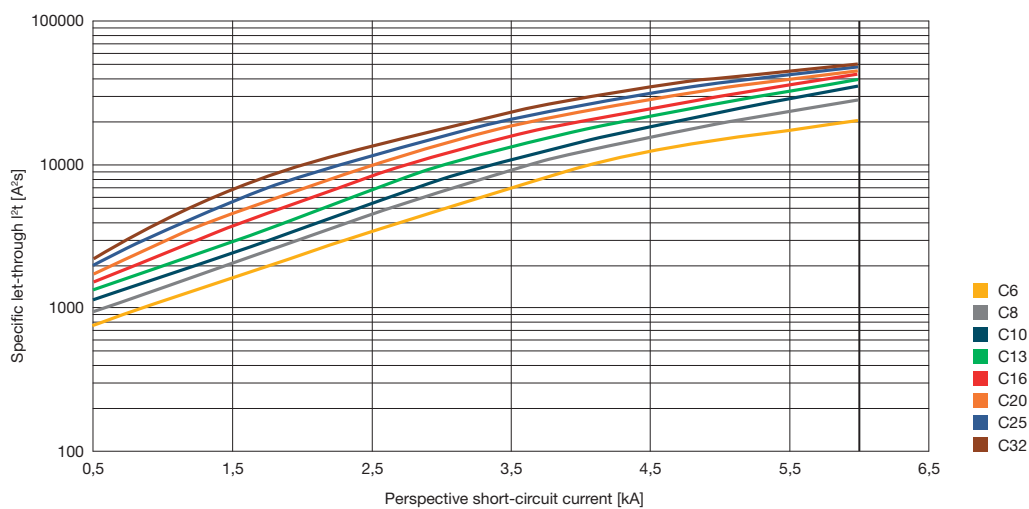

#### DS203NC, characteristic K

400 V let-through energy

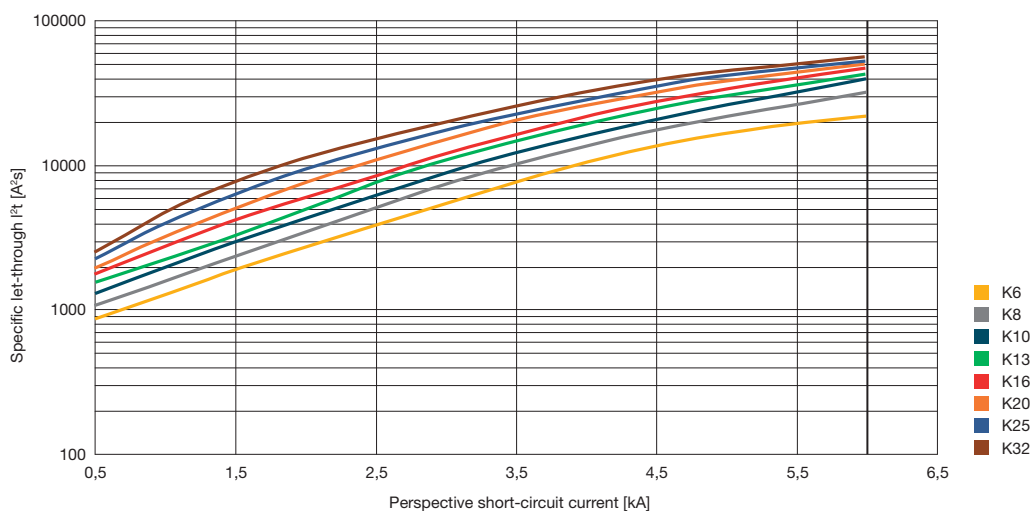



## RCDs technical details

### Limitation of specific let-through energy $I^2t$

#### DSE201

230 V let-through energy

DSE201, characteristic B

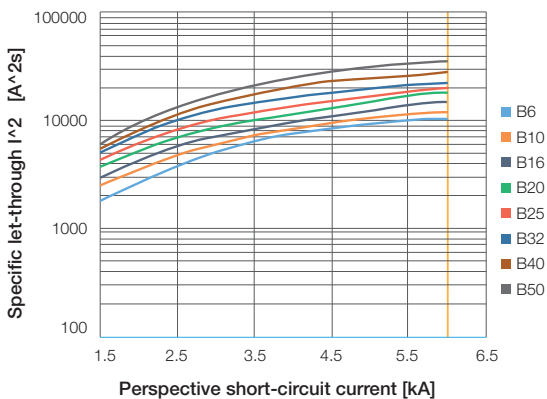

DSE201, characteristic C

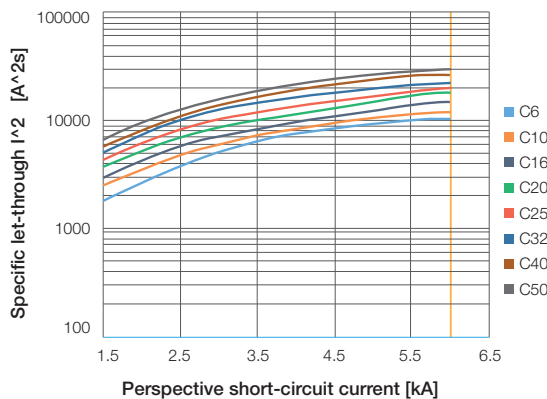

#### DSE201 M

230 V let-through energy

DSE201M, characteristic B

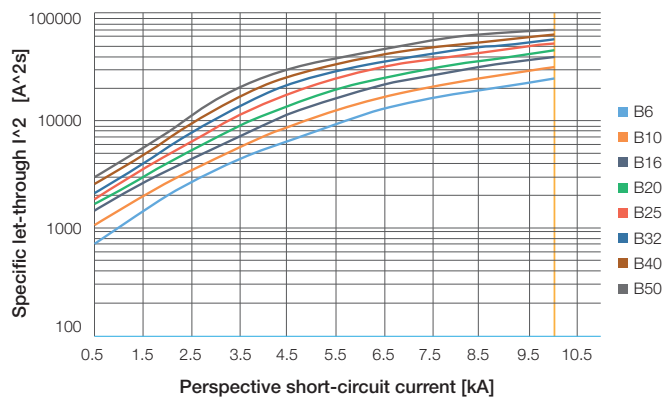

DSE201M, characteristic C

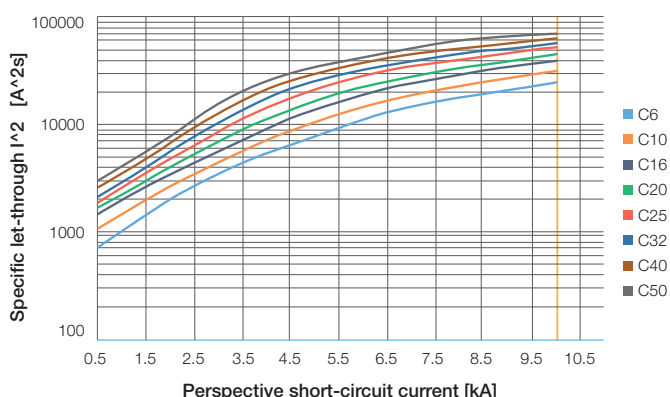

## RCDs technical details

### Limitation of specific let-through energy $I^2t$

#### DSN201E, DSE201 NS

230 V let-through energy

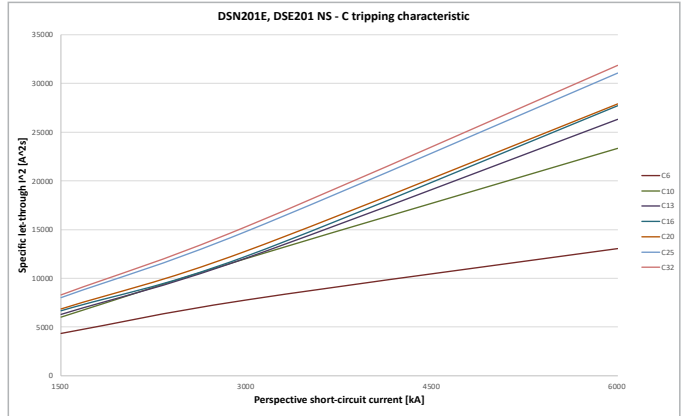
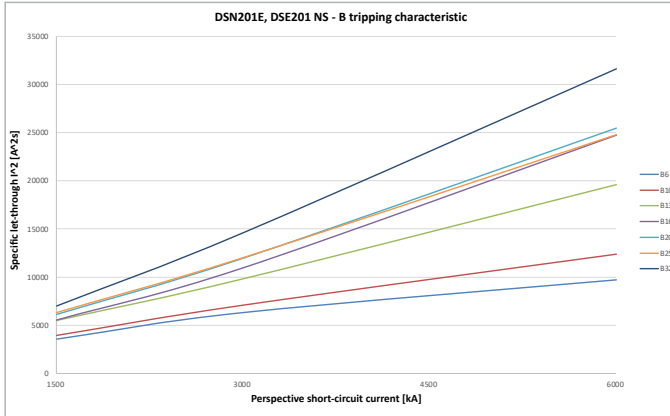

#### DSN201EM, DSE201M NS

230 V let-through energy

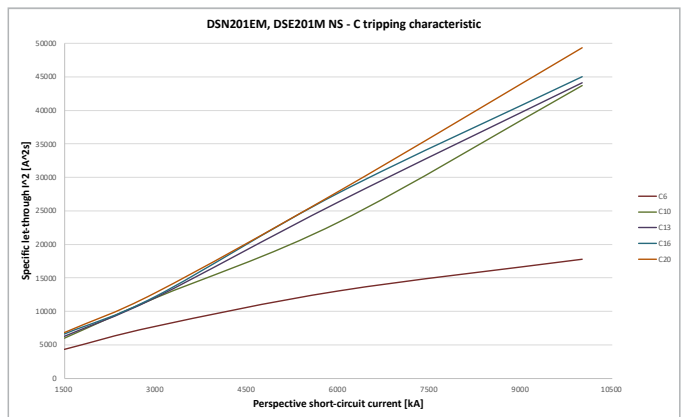
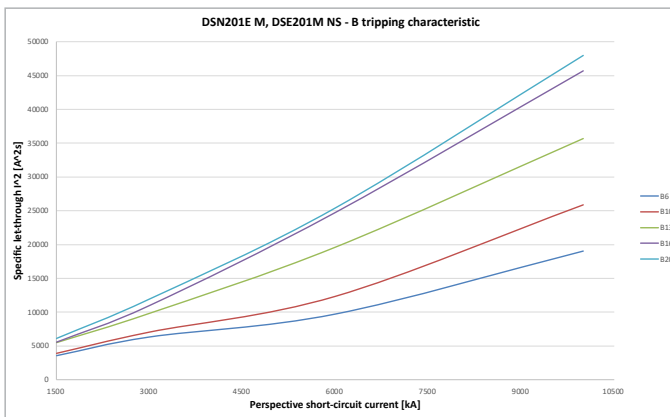

## RCDs technical details

### Limitation of specific let-through energy $I^2t$

#### DSE203 M, DSE203N M, DSE203NS M

400 V let-through energy

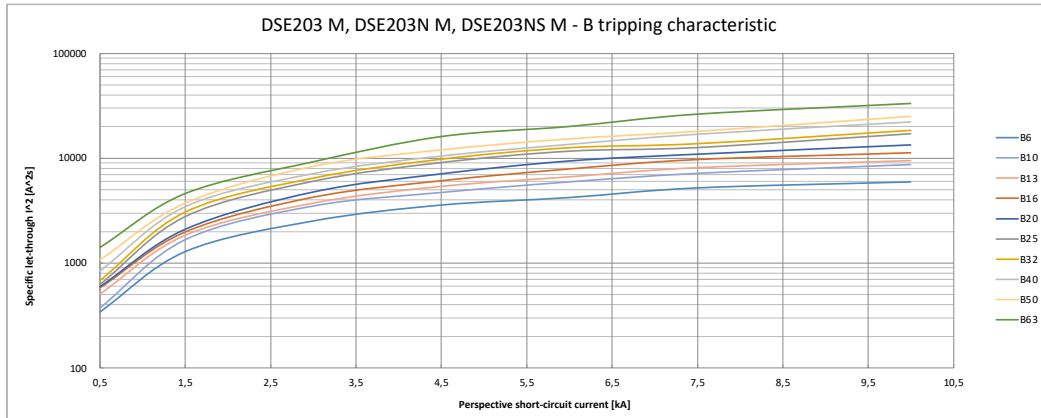

#### DSE203 M, DSE203N M, DSE203NS M

400 V let-through energy

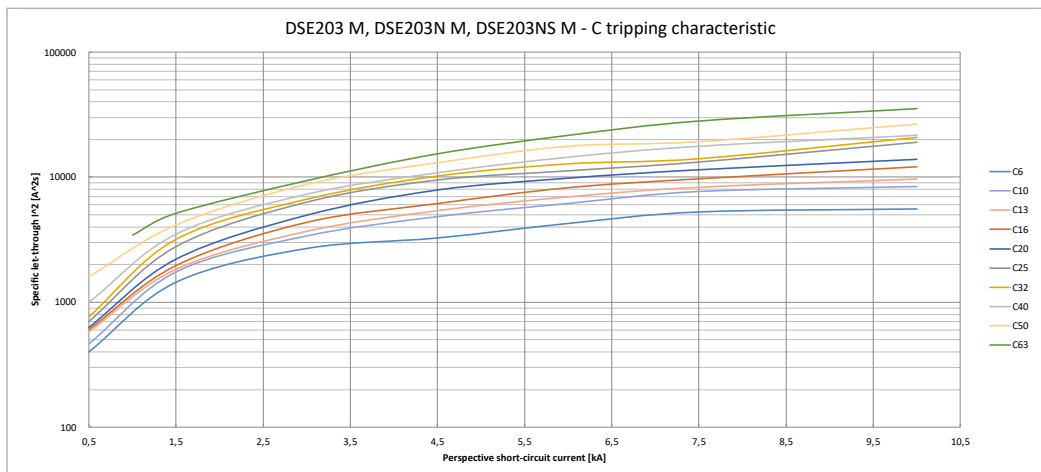

#### DSE203 M, DSE203N M, DSE203NS M

400 V let-through energy

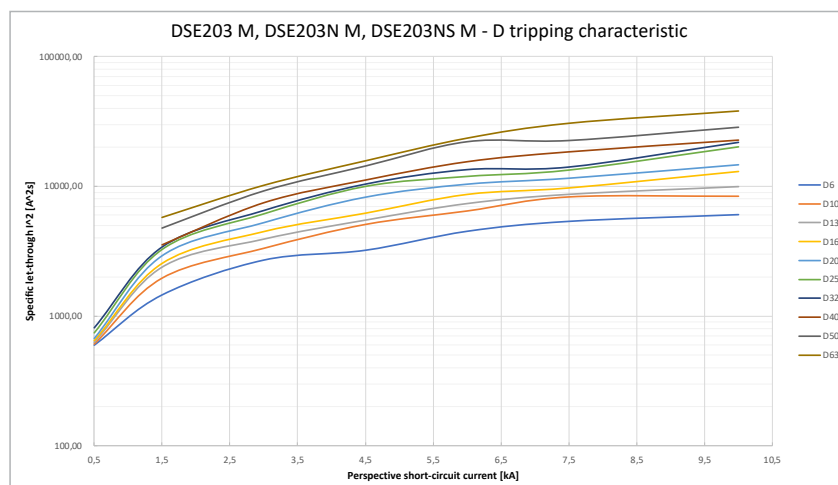

# RCDs technical details

Peak current  $I_p$

**DS201 L - DS201 - DS201 T - DS201 M**  
 characteristics B e C  
 230 V

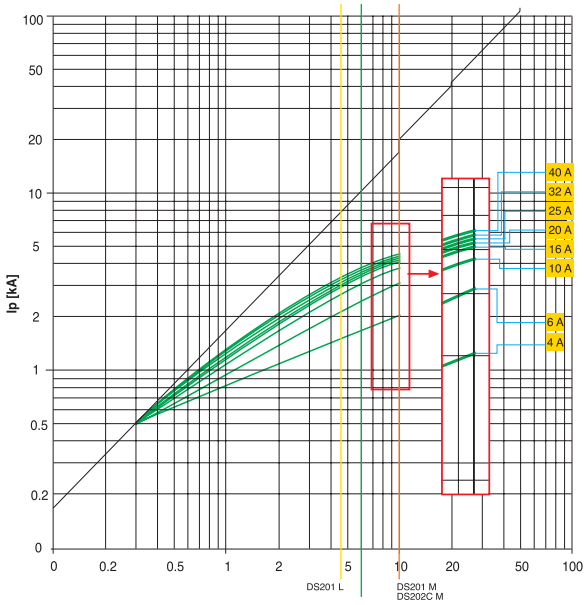

**DS202CR - DS202CR M**  
 characteristics B and C  
 230 V

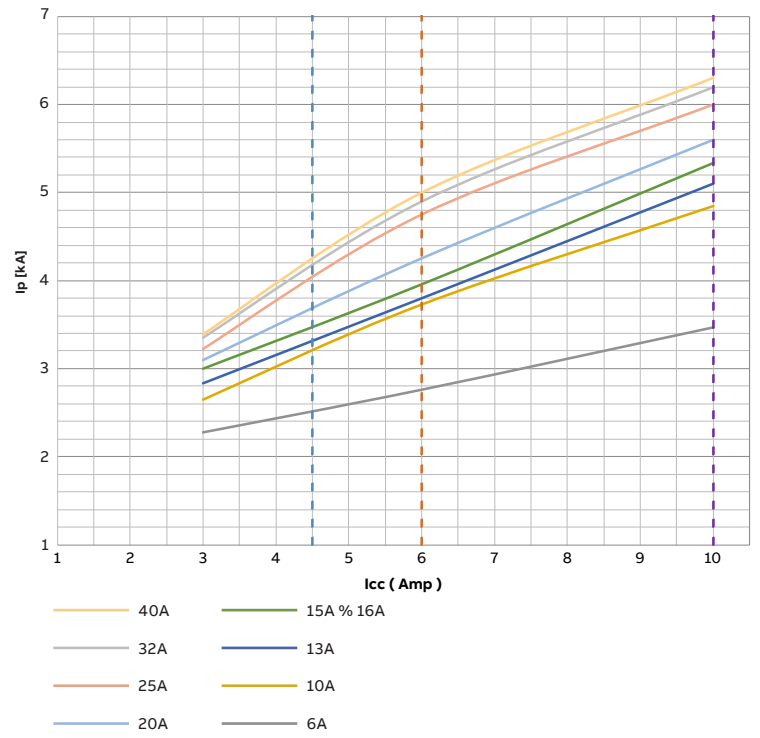



## RCDs technical details

### Peak current $I_p$

**$I_{peak}$  DS201L - Characteristic C**

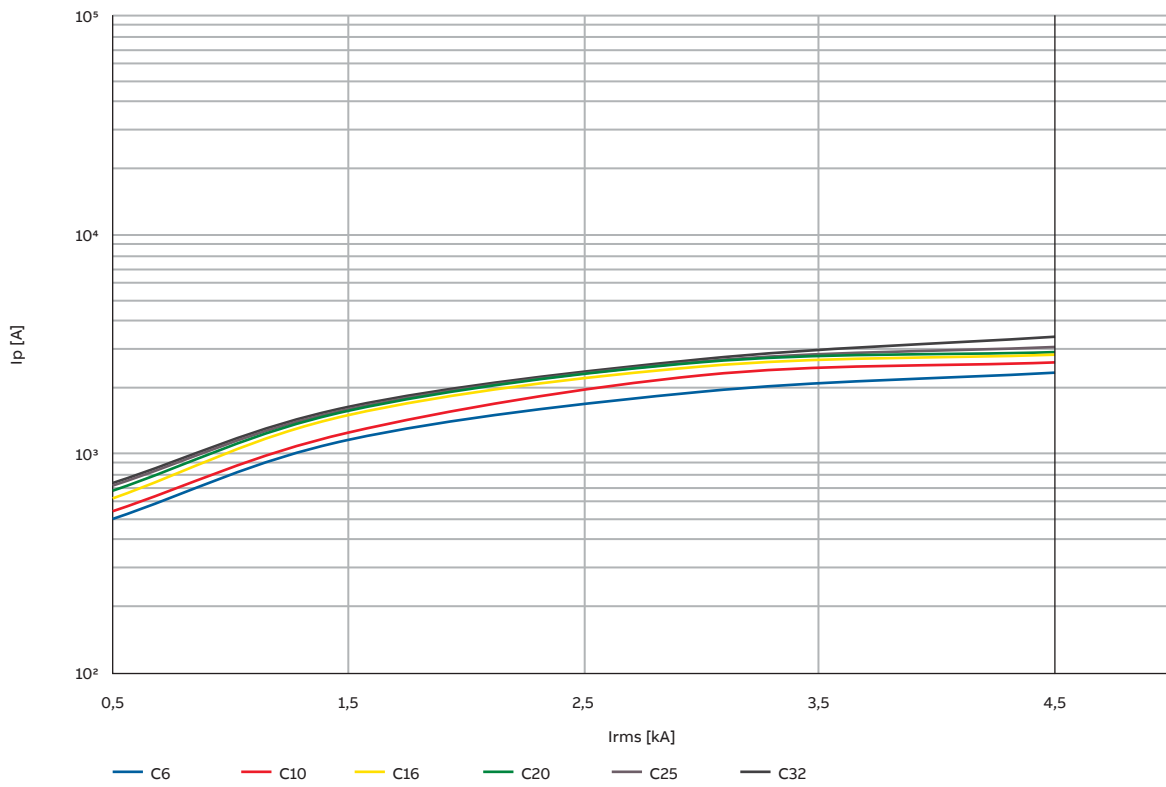

**$I_{peak}$  DS201 - Characteristic B**

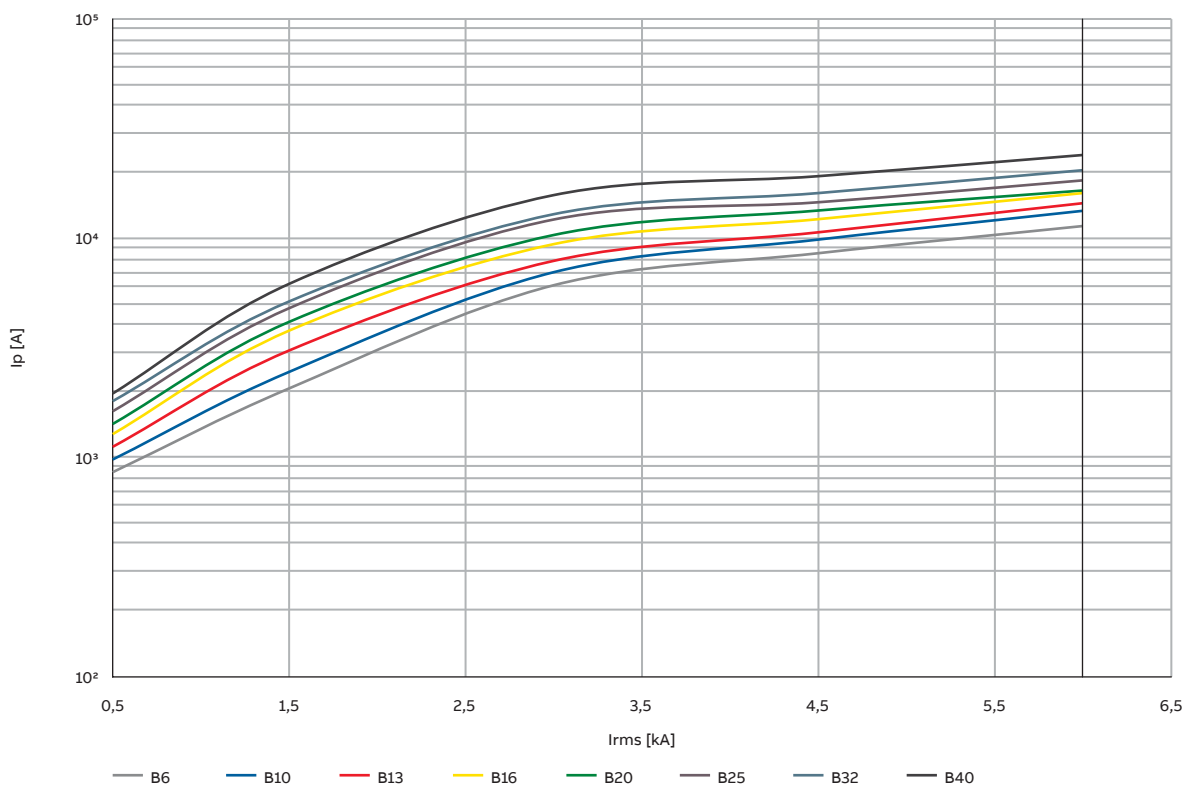

## RCDs technical details

Peak current  $I_p$

### $I_{peak}$ DS201 - Characteristic C

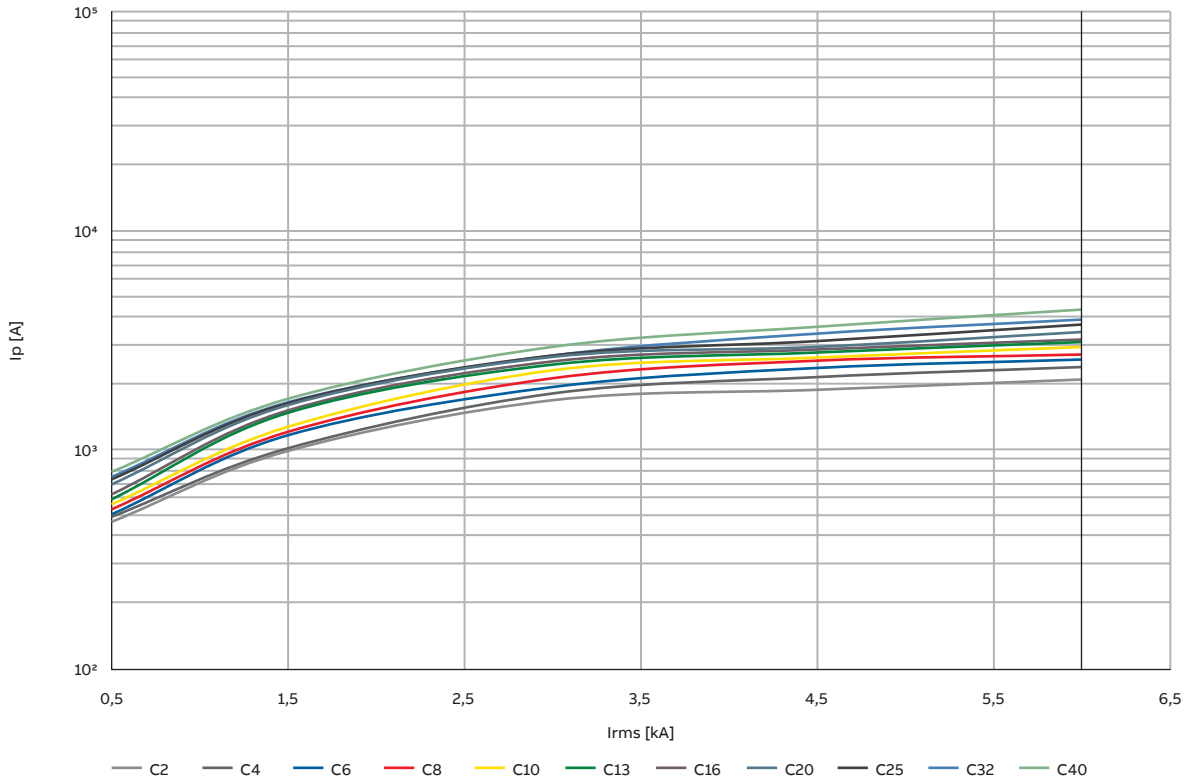

### $I_{peak}$ DS201 - Characteristic K

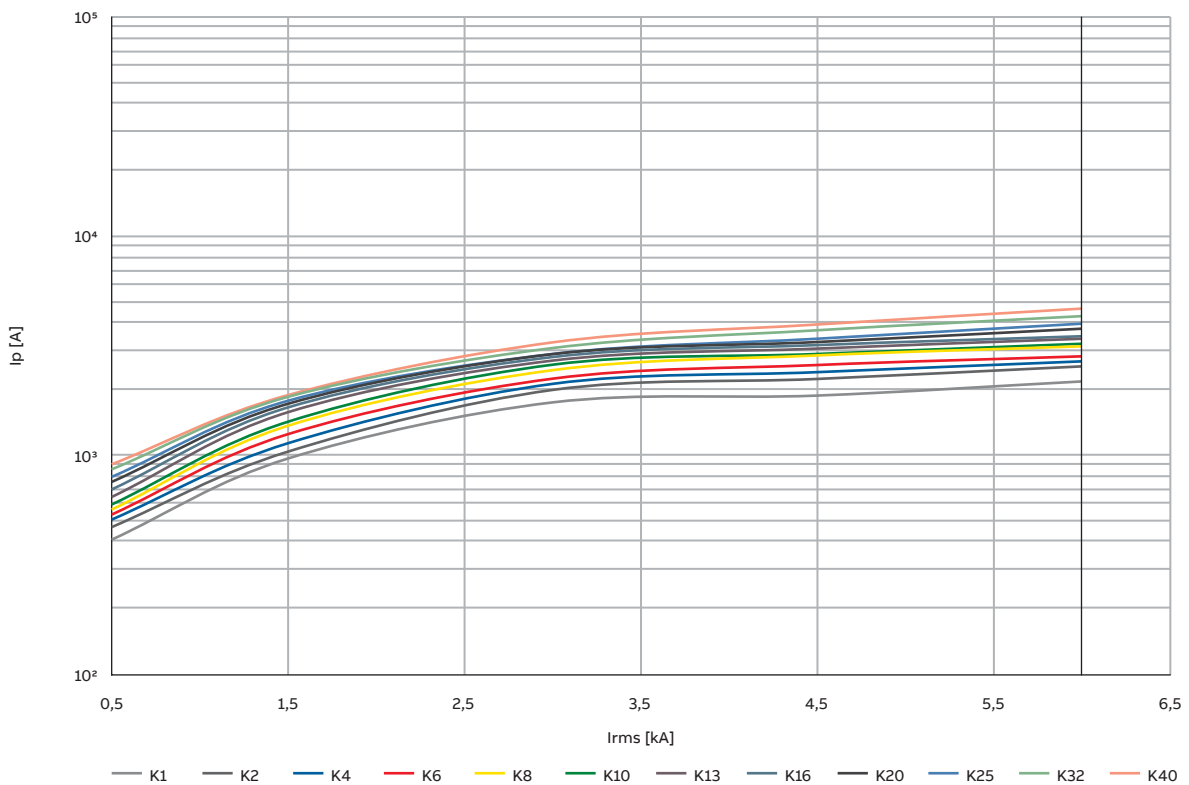

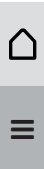

# RCDs technical details

## Peak current $I_p$

### $I_{peak}$ DS201M - Characteristic B

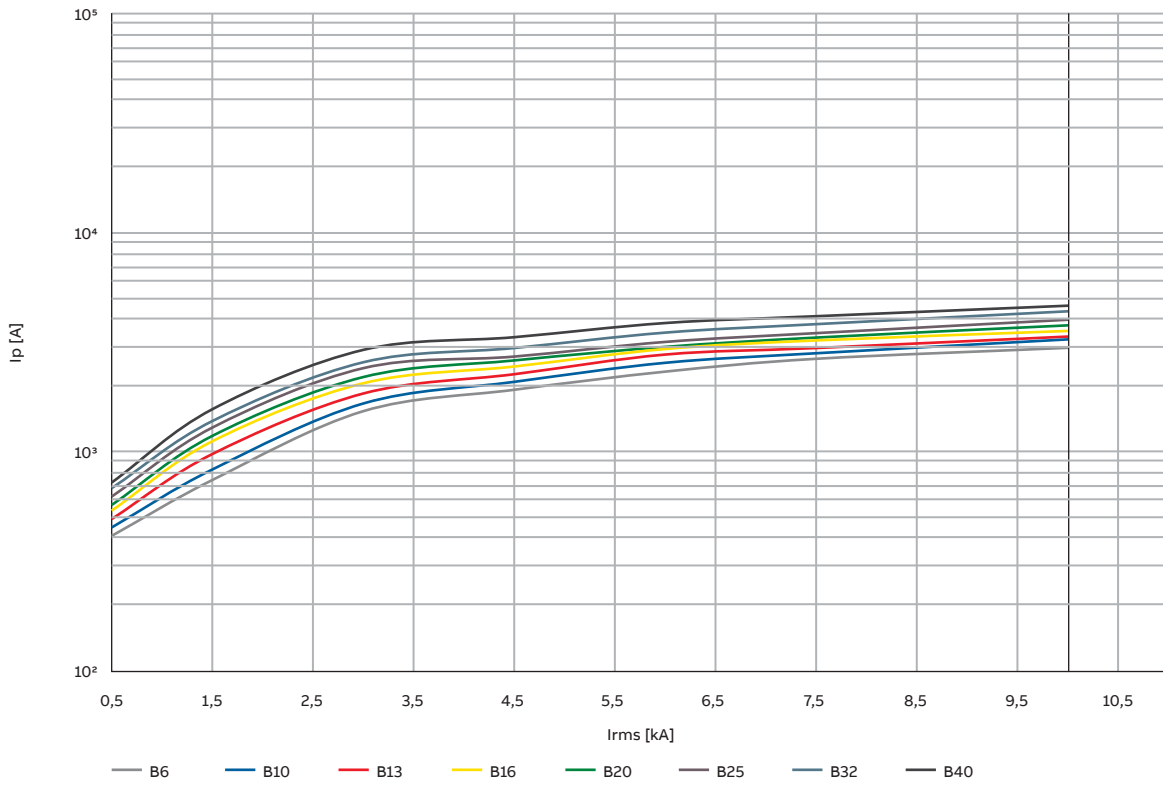

### $I_{peak}$ DS201M - Characteristic C

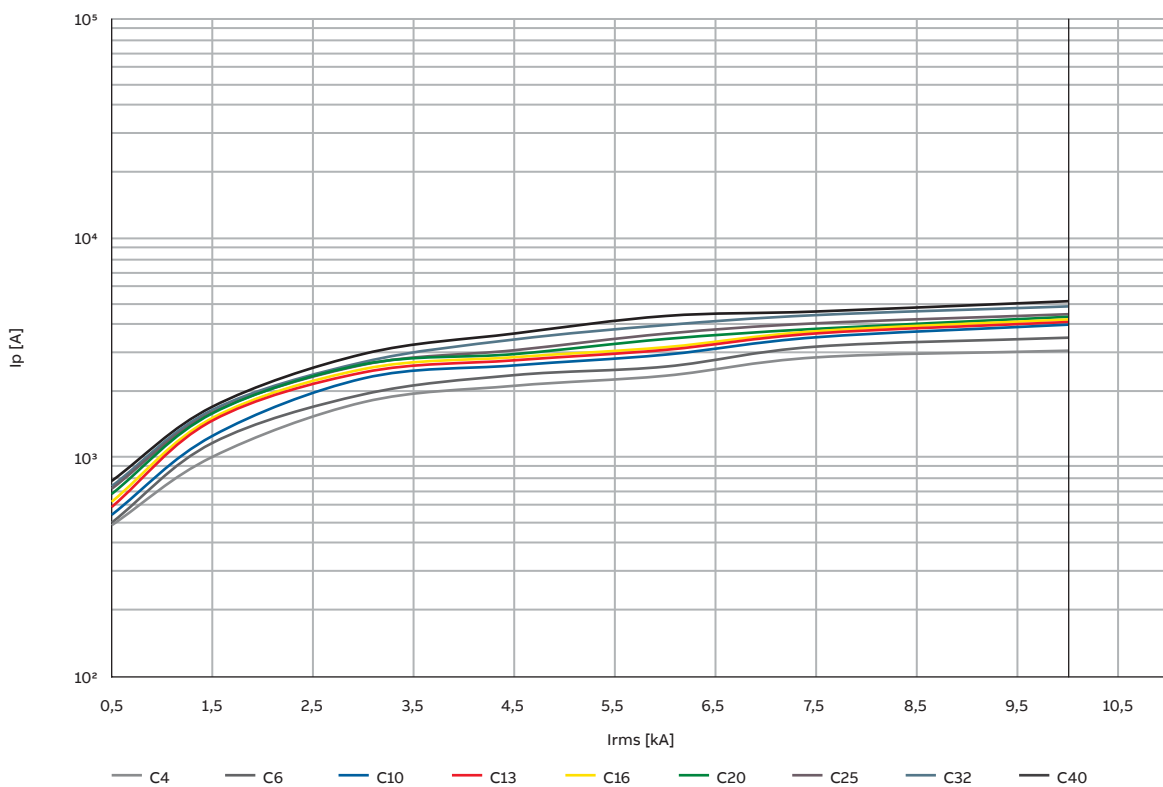

## RCDs technical details

Peak current  $I_p$

### $I_{peak}$ DS201M - Characteristic K

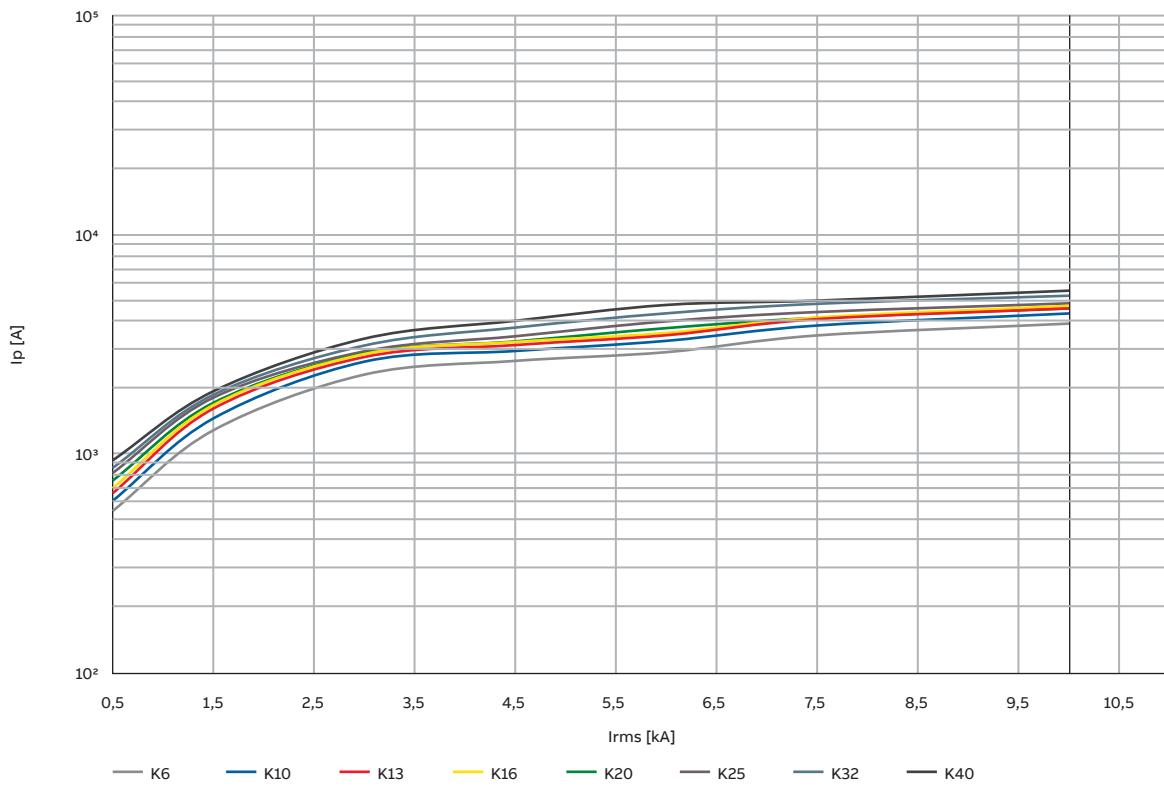



# RCBO DS301C

## Technical data

### I<sub>peak</sub> DS301C—Characteristic C

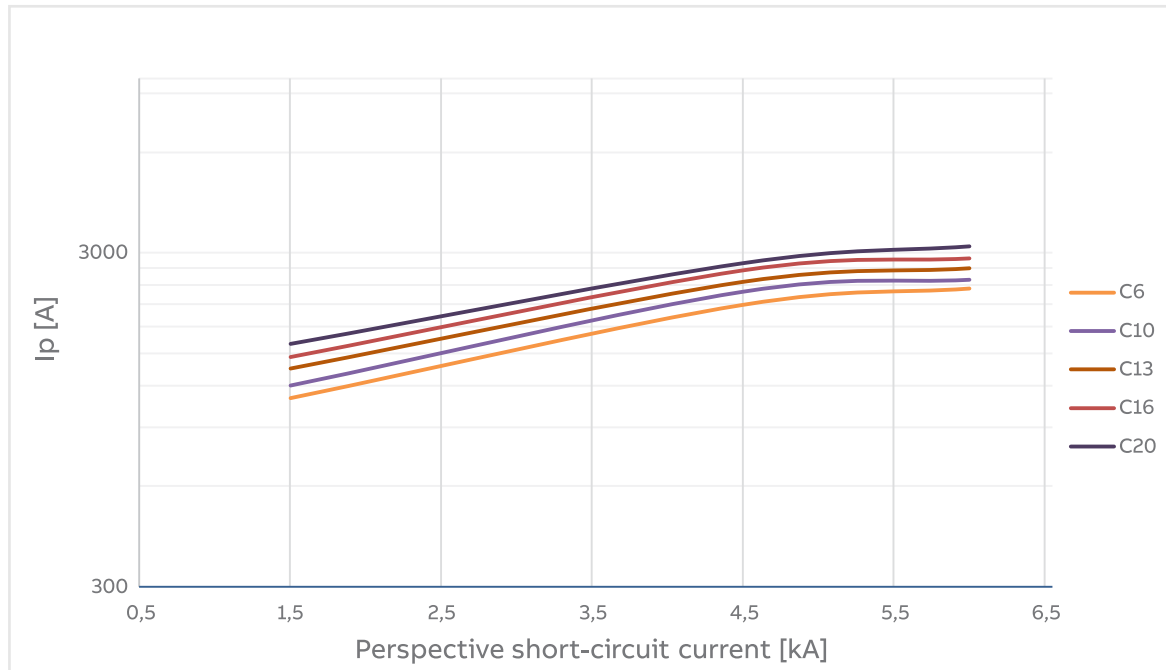

### I<sub>peak</sub> DS301C—Characteristic B

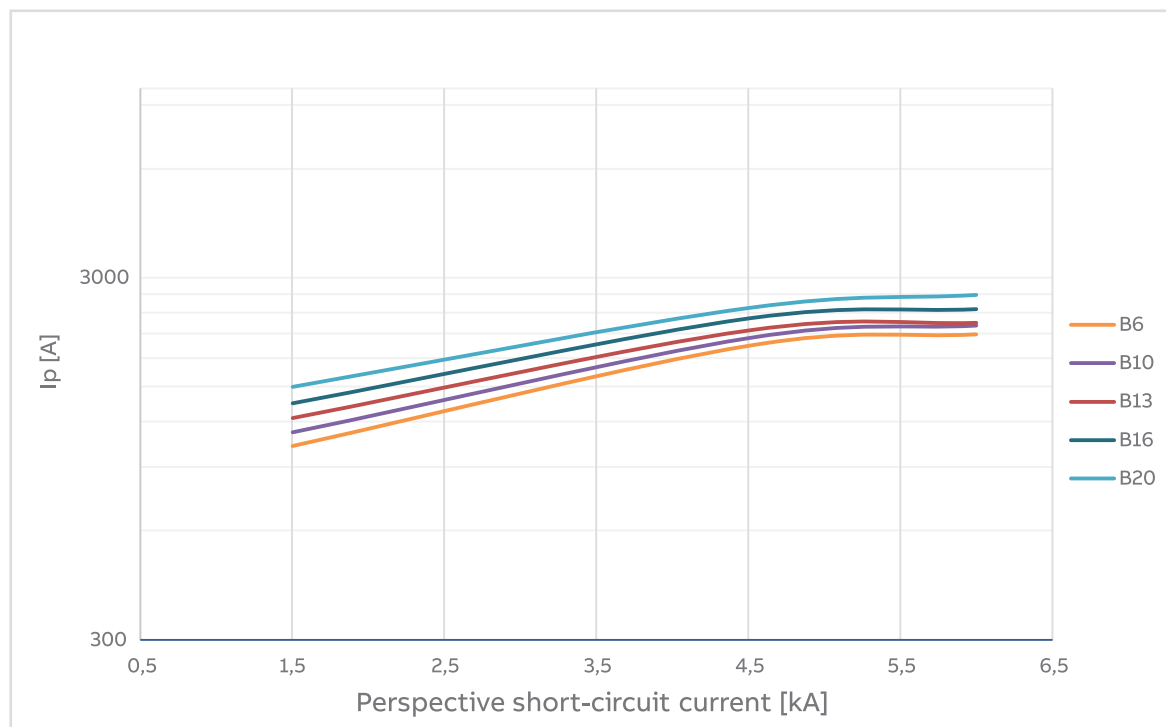

# RCDs technical details

## Peak current $I_p$

DS203NC L, characteristic B

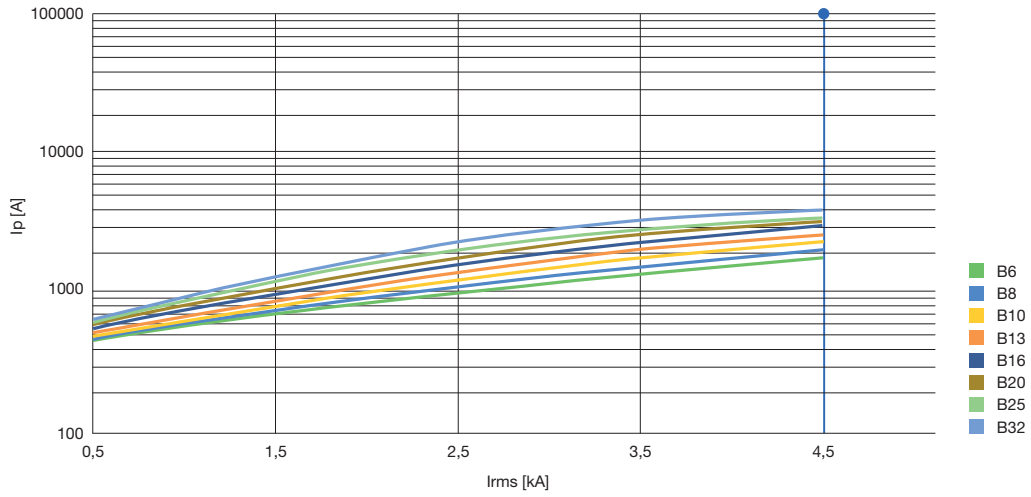

DS203NC, characteristic B

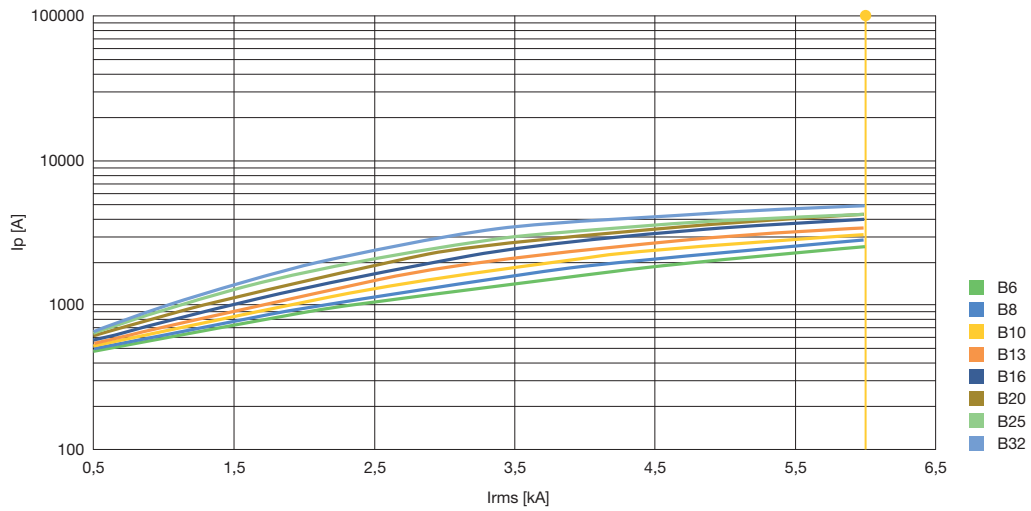



# RCDs technical details

## Peak current $I_p$

DS203NC L, characteristic C

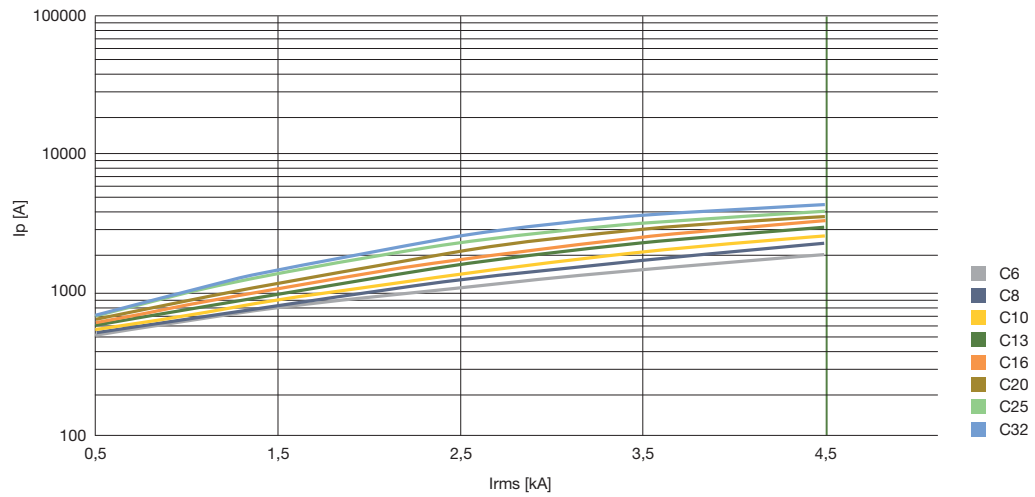

DS203NC, characteristic C

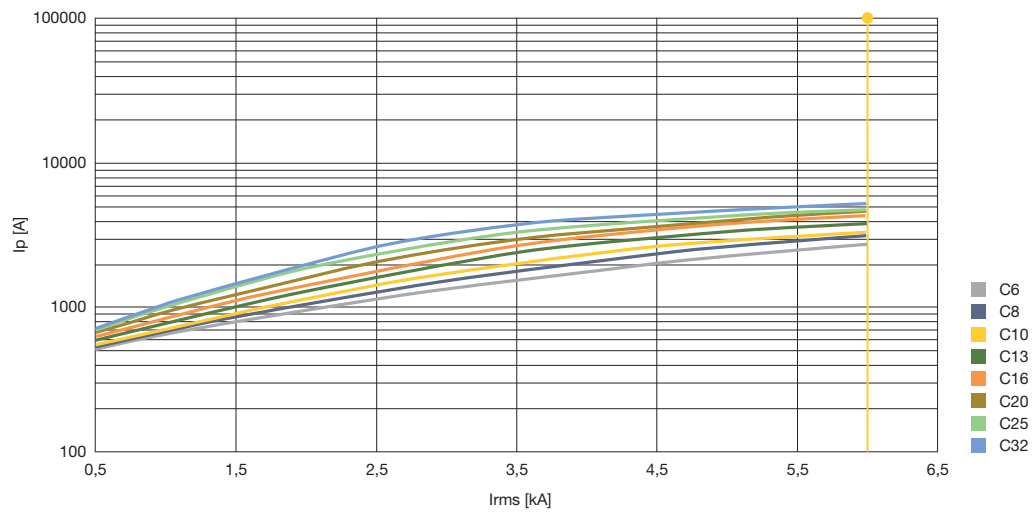

DS203NC, characteristic K

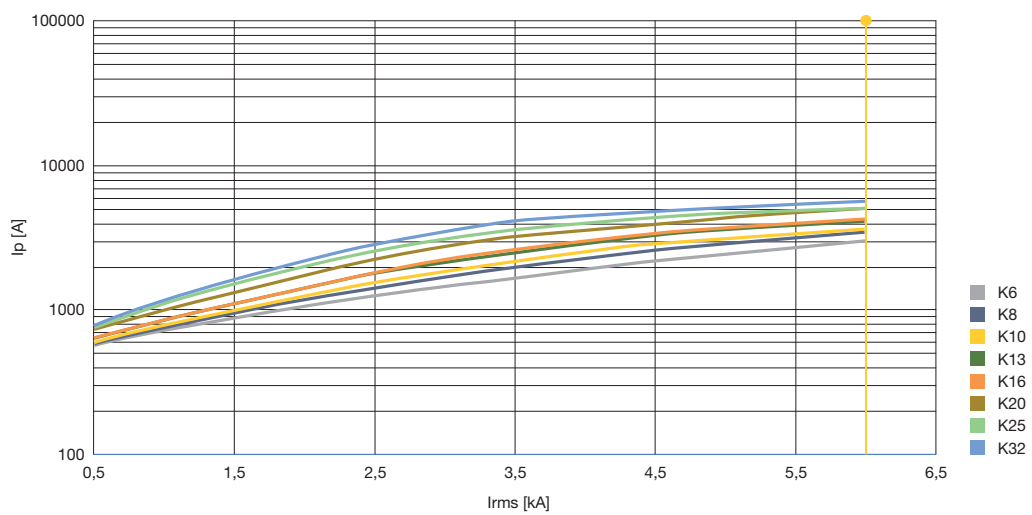

# RCDs technical details

## Peak current $I_p$

### DSE201

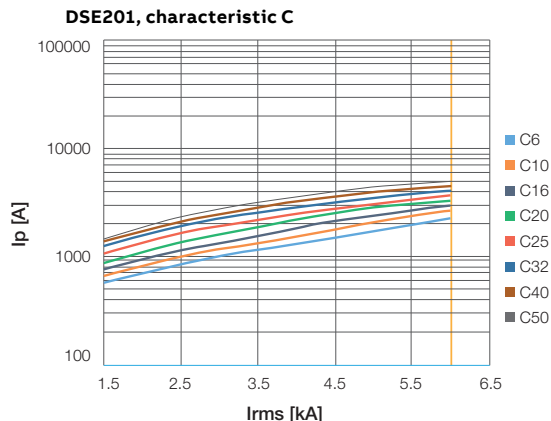
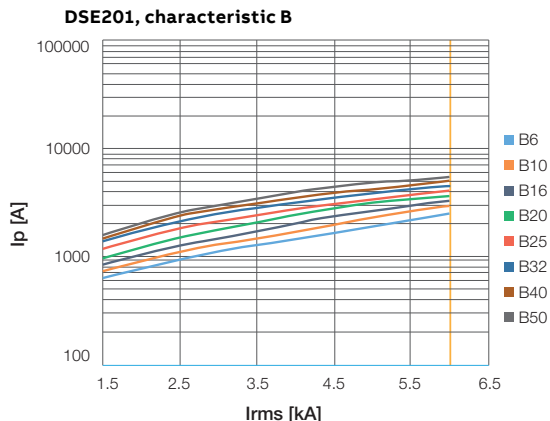

### DSE201 M

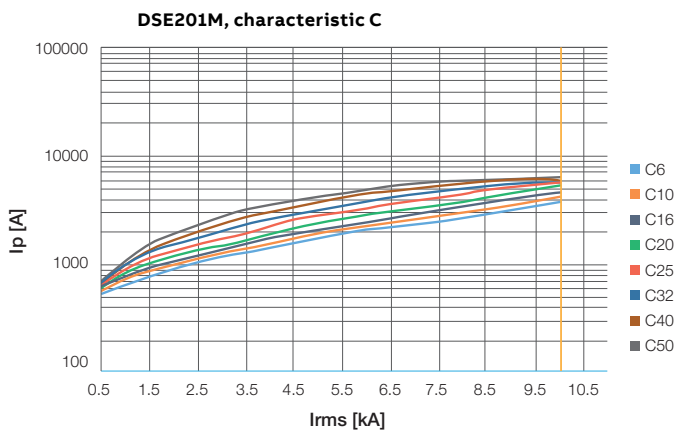
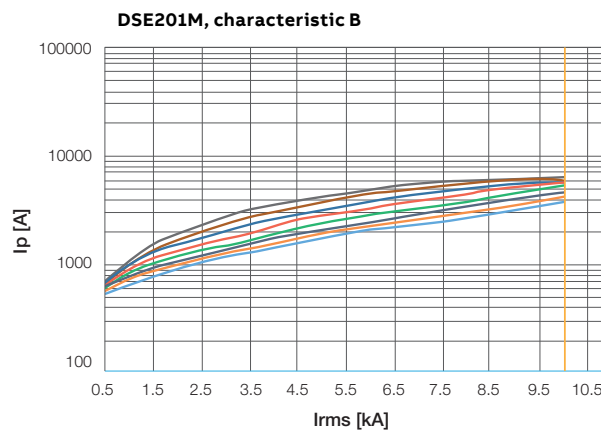

### DSE203 M / DSE203N M / DSE203NS M

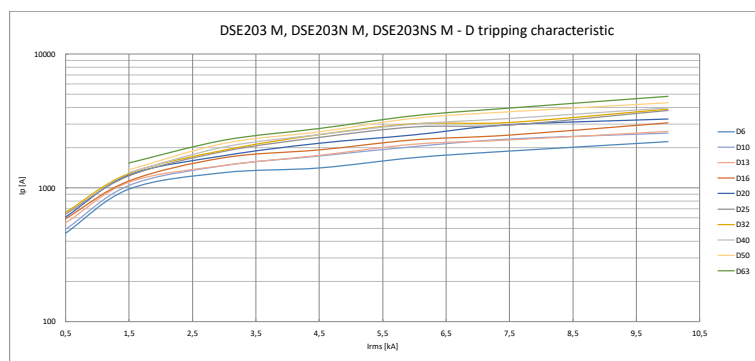
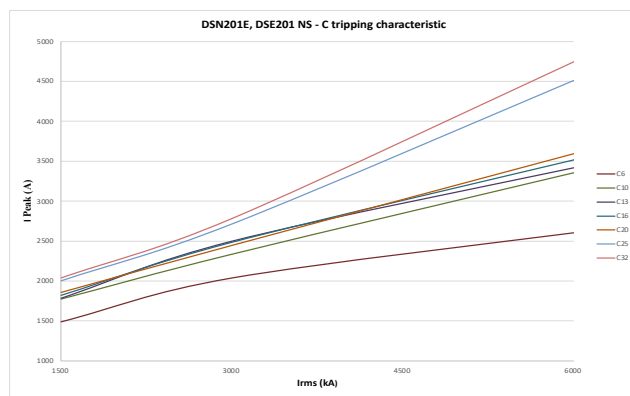
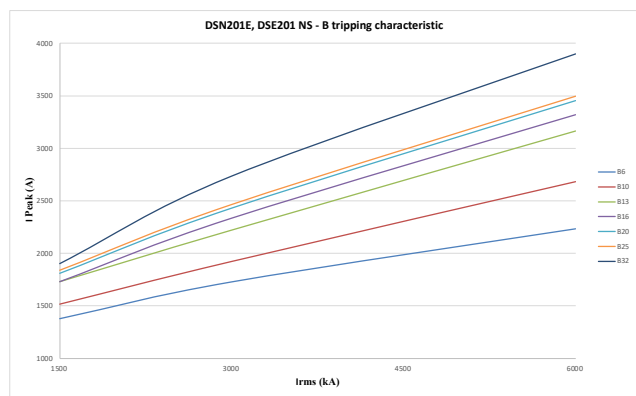



# RCDs technical details

## Peak current $I_p$

### DSN201E, DSE201 NS

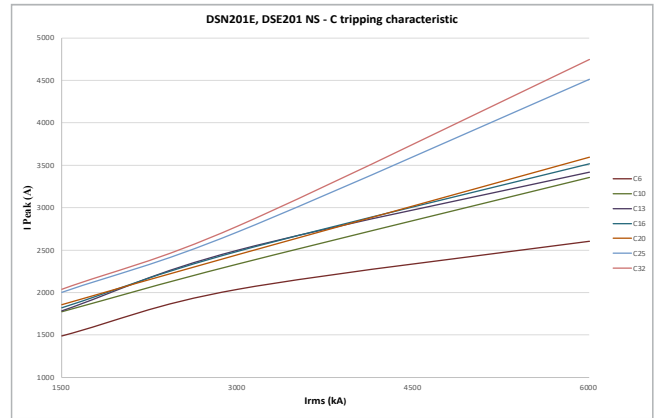
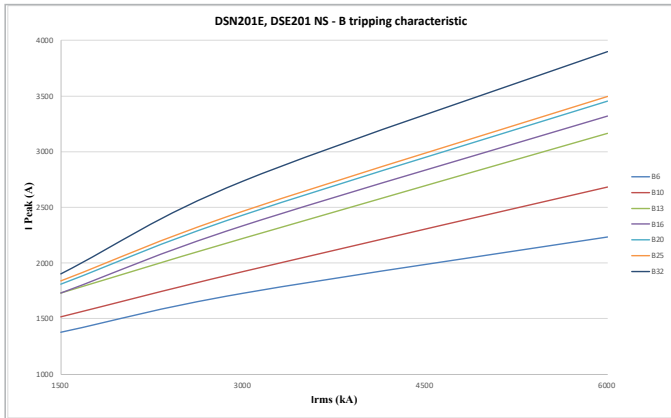

### DSN201EM, DSE201M NS

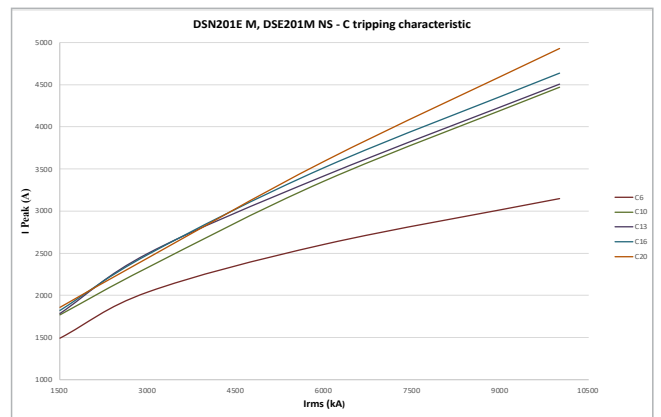
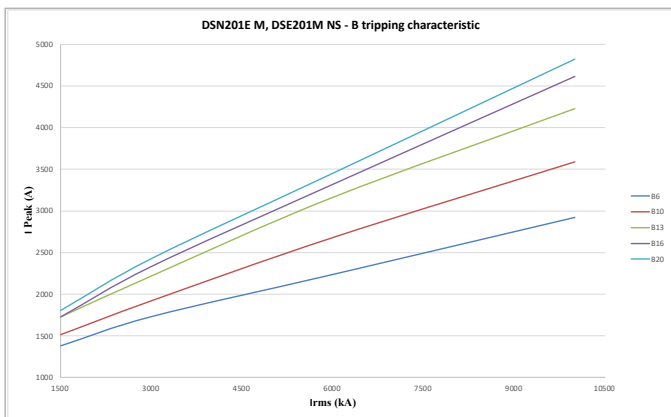

## RCDs technical details

### Peak current $I_p$

#### DSE203 M, DSE203N M, DSE203NS M

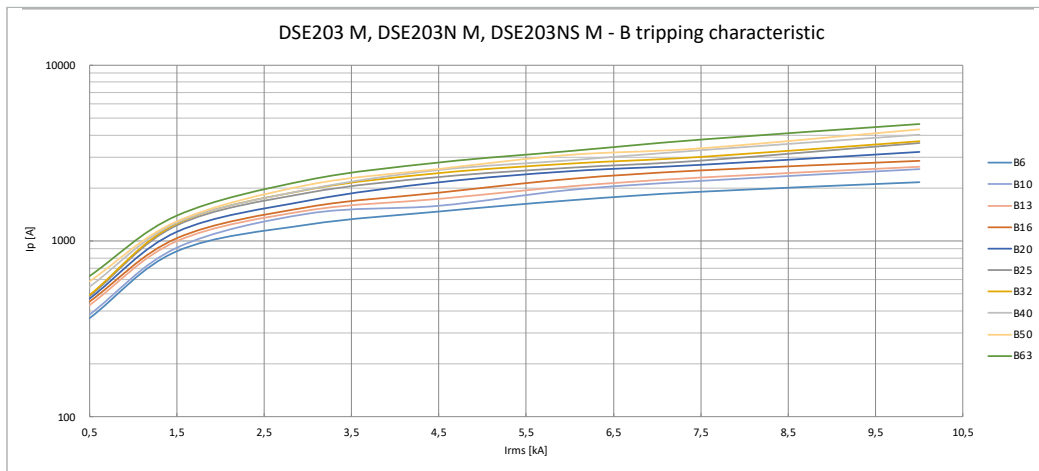

#### DSE203 M, DSE203N M, DSE203NS M

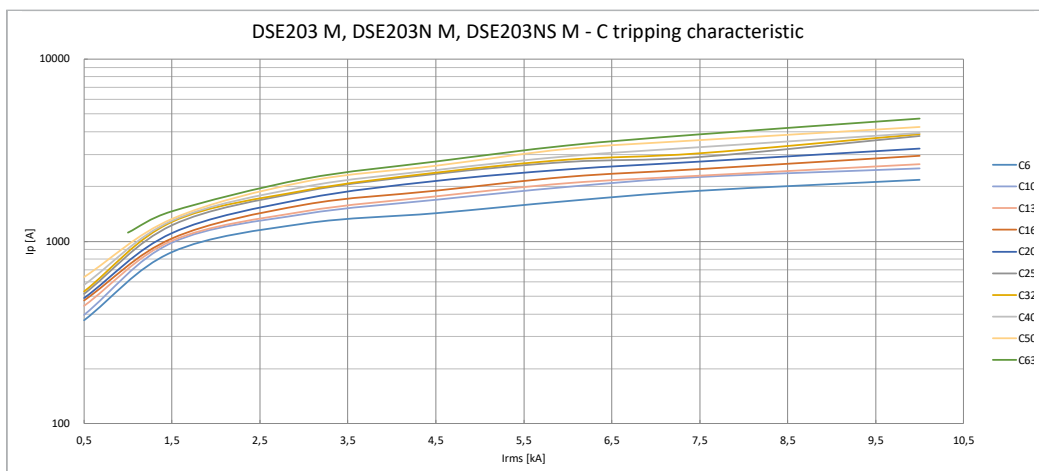

#### DSE203 M, DSE203N M, DSE203NS M

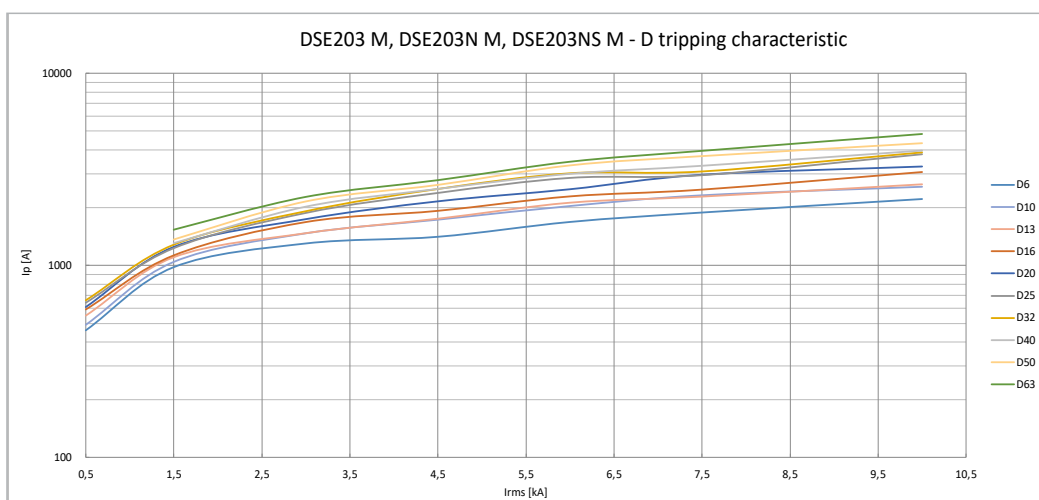

# RCDs technical details

## SOC - Selected Optimized Coordination



ABB is constantly improving or developing new products. Coordination between these products is therefore constantly updated. Providing always the up-to-date version in an environmental-friendly way the World Wide Web is a perfect platform. Therefore ABB offers a new tool online, SOC – Selected Optimized Coordination.

SOC is a web tool for the selection of ABB products in these applications:

- Motor starting and protection
- Selectivity between protection devices
- Back-up protection
- Other devices protection

Please check out under:

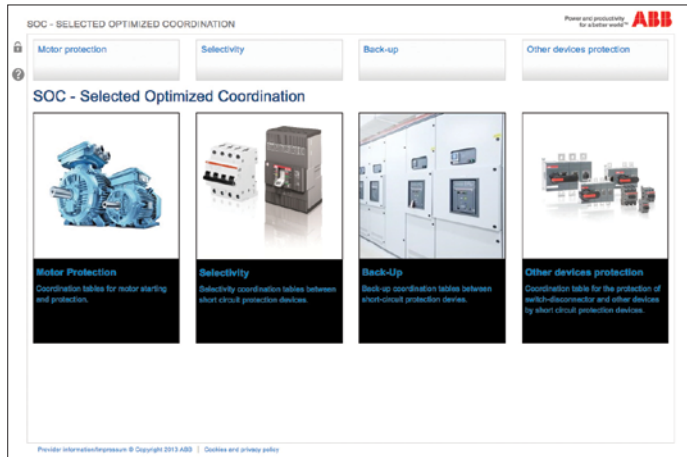
<https://www.lowvoltage-tools.abb.com/soc/>

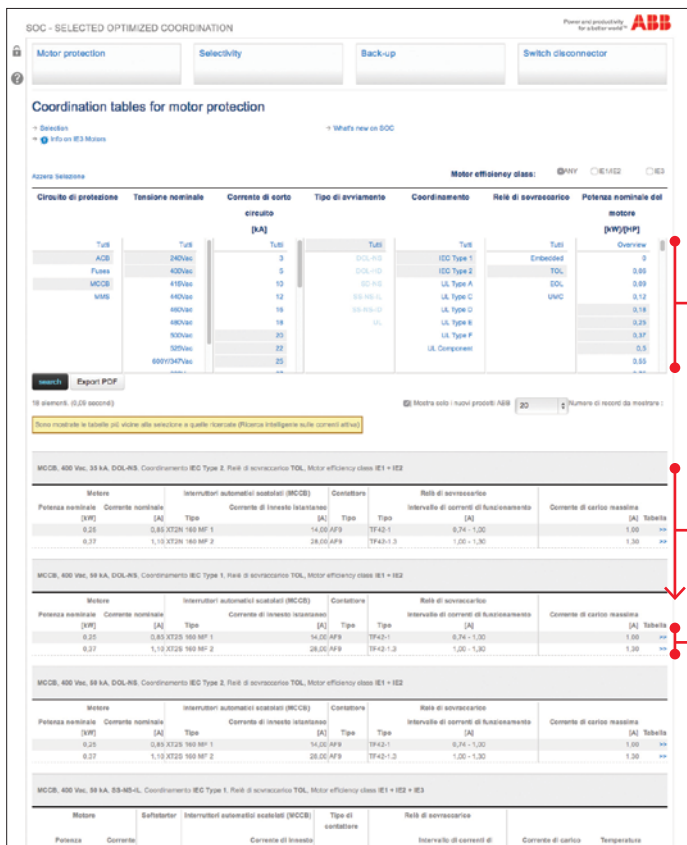

In the on line coonfigurator you can choose among many filters, it is possible to select more than one filter at the same time. For selectivity and back-up coordination tables please choose the upstream voltage and the downstream voltage to display the tables.

Results are shown in the bottom part of the page. If a search does not produce any result, “Smart Search” will show the closest tables matching the search criteria.

Click on “>>” on the rightmost part of each record, to view the whole coordination table, tables can be printed or saved as PDF files.

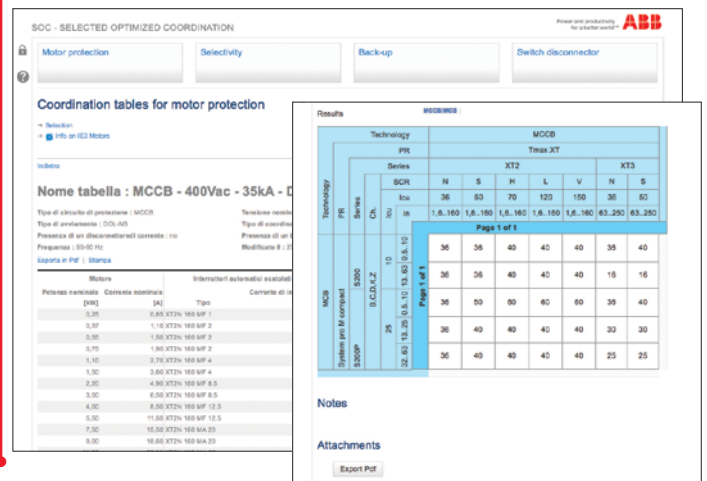

## RCDs technical details

### Coordination tables: residual current protection selectivity

#### Selectivity

RCDs raise similar issue to those surrounding the installation of MCBs, and in particular the need to reduce to a minimum the parts of the system out of order in the event of a fault. For RCBOs the problem of selectivity in the case of short-circuit currents may be handled with the same specific criteria as for MCBs.

However, for correct residual current protection, the more important aspects are linked to tripping times. Protection against contact voltages is only effective if the maximum times indicated on the safety curve are not exceeded. If an electrical system has user devices with earth leakage currents which exceed the normal values (e.g.: presence of capacitor input filters inserted between the device phase and earth cables) or if the system consists of many user devices, it is good practice to install various RCDs, on the main branches, with an upstream main residual current or non-residual current device instead of a single main RCD.

#### Horizontal selectivity

The non-residual current main circuit-breaker provides “horizontal selectivity”, preventing an earth fault at any point on the circuit or small leakage from causing unwanted main circuit-breaker tripping, which would put the entire system out of order.

However, in this way, section k of the circuit between the main circuit-breaker and the RCDs remains without “active” protection. Using a main RCD to protect it would lead to problems with “vertical selectivity”, which require tripping of the various devices to be co-ordinated, so that service continuity and system safety are not compromised. In this case, selectivity may be amperometric (partial) or chronometric (total).

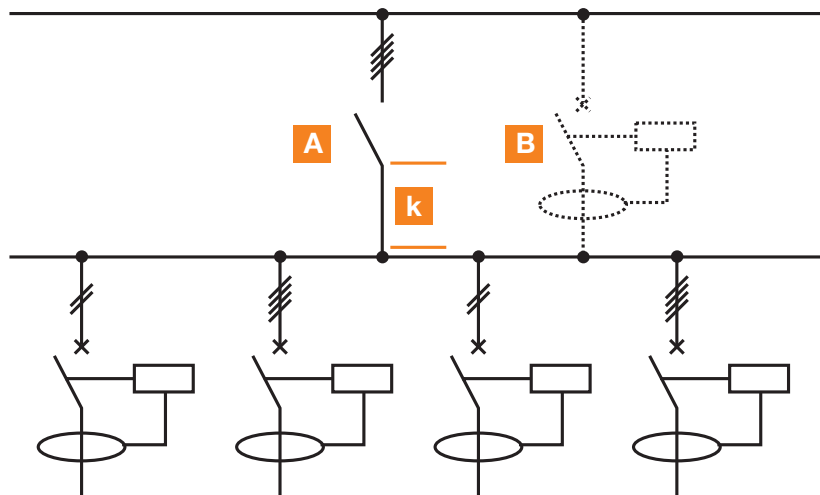

#### Vertical selectivity

Vertical selectivity may also be established for residual current tripping, bearing in mind that in working back from system peripheral branches to the main electrical panels the risk of unskilled persons coming into contact with dangerous parts is significantly reduced.

## RCDs technical details

### Coordination tables: residual current protection selectivity

#### Amperometric (partial) selectivity

Selectivity may be created by placing low-sensitivity RCDs upstream and higher-sensitivity RCDs downstream. An essential condition which must be satisfied in order to achieve selective co-ordination is that the  $I_{\Delta 1}$  value of the breaker upstream (main breaker) is more than double the  $I_{\Delta 2}$  value of the breaker downstream. The operative rule to obtain an amperometric (partial) selectivity is  $I_{\Delta n}$  of the

upstream breaker =  $3 \times I_{\Delta n}$  of the downstream breaker (e. g.: F 204, A type, 300 mA upstream; F 202, A type, 100 mA downstream).

In this case, selectivity is partial and only the downstream breaker trips for earth fault currents  $I_{\Delta 2} < I_{\Delta m} < 0.5 \cdot I_{\Delta 1}$ .

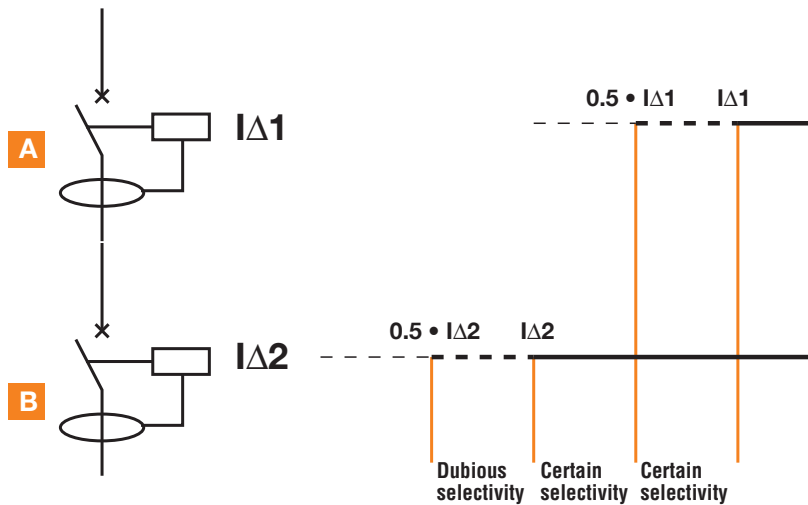

#### Chronometric (total) selectivity

To achieve total selectivity, delayed or selective RCDs must be installed.

The tripping times of the two devices connected in series must be co-ordinated so that the total interruption time  $t_2$  of the downstream breaker is less than the upstream breaker's no-response limit time  $t_1$ , for any current value. In this way, the downstream breaker completes its opening before the upstream one.

To completely guarantee total selectivity, the  $I_{\Delta}$  value of the upstream device must also be more than double that of the downstream device in accordance with IEC 64-8/563.3, comments. The operative rule to obtain an chronometric (total) selectivity is  $I_{\Delta n}$  of the upstream breaker =  $3 \times I_{\Delta n}$  of the downstream breaker (e. g.: F 204, S type, 300 mA upstream; F 202, A type, 100 mA downstream). For safety reasons, the delayed tripping times of the upstream breaker must always be below the safety curve.

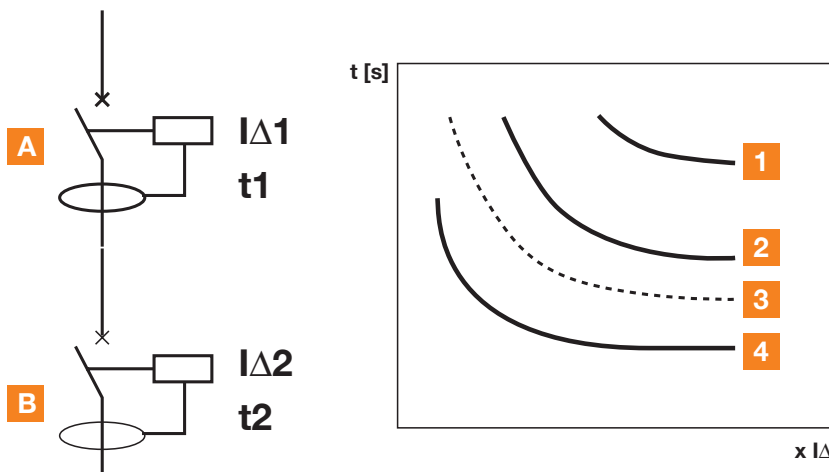

#### Legend

- 1 Theoretical safety curve
- 2 RCD A tripping characteristic
- 3 No-response limit times
- 4 RCD B tripping characteristic

## RCDs technical details

### Coordination tables: residual current protection selectivity

Table of RCD selectivity

	Upstream I $\Delta$ n [mA]	10	30	100	300	300	500	500	1000	1000
Downstream I $\Delta$ n [mA]	inst	inst	inst	inst	inst	S	inst	S	inst	S
10	inst		▲	▲	▲	■	▲	■	▲	■
30	inst			▲	▲	■	▲	■	▲	■
100	inst				▲	■	▲	■	▲	■
300	inst								▲	■
300	S								▲	▲
500	inst									
500	S									
1000	inst									
1000	S									

inst = instantaneous S = selective ▲ = amperometric (partial) selectivity ■ = chronometric (total) selectivity

### Back-up F-ATI Test and F-ARI Test

The values has to be delivered from the LAB

2P	Rated current [A]	25	40	63	80	100
Single phase circuit with neutral 230- 240 V	Fuse gG 25A	10				
	Fuse gG 40A	10	10			
	Fuse gG 63A	10	10	10		
	Fuse gG 100A	10	10	10		
	S800 S	6	9	10		
	S800 N	6	9	10		
	S200	7	7	5		
	S200 M	7	7	5		
	S200 P	7	7	5		
	S300 P	7	7	5		
4P	Rated current [A]	25	40	63	80	100
Three phase circuit with neutral 400- 415 V	Fuse gG 25A	10				
	Fuse gG 40A	10	10			
	Fuse gG 63A	10	10	10		
	Fuse gG 100A	10	10	10	10	10
	S800 S	10	10	10	10	10
	S800 N	10	10	10	10	10
	S200	10	10	10	10	10
	S200 M	10	10	10	10	10
	S200 P	10	10	10	10	10
	S300 P	10	10	10	10	10



## RCDs technical details

### Coordination tables: residual current protection selectivity

#### Back-up F-ATI Test 2 & 4 pole with MCB S800S, S800N

Upstream technology		MCB	MCB	MCB	MCB	MCB	MCB	MCB	MCB	MCB	MCB		
RCD	System pro M compact	Product Range	S800	S800	S800	S800	S800	S800	S800	S800	S800	S800	
		Series	S800S	S800S	S800S	S800S	S800S	S800N	S800N	S800N	S800N	S800N	S800N
			Characteristics	B,C,D,K	B,C,D,K	B,C,D,K	B,C,D,K	B,C,D,K	B,C,D	B,C,D	B,C,D	B,C,D	B,C,D
		Icu	50	50	50	50	50	36	36	36	36	36	36
			In	25	32	40	50	63	25	32	40	50	63
		A	10	25	20				15				
		A	10	40	20	20	20		15	15	15		
		A	10	63	20	20	20	20	15	15	15	15	15
		A	10	25	20				15				
		A	10	40	20	20	20		15	15	15		
A	10	63	20	20	20	20	15	15	15	15	15		

Upstream technology		MCB	MCB	MCB	MCB	MCB	MCB	MCB	MCB	MCB	MCB		
RCD	System pro M compact	Product Range	S800	S800	S800	S800	S800	S800	S800	S800	S800	S800	
		Series	S800S	S800S	S800S	S800S	S800S	S800N	S800N	S800N	S800N	S800N	S800N
			Characteristics	B,C,D,K	B,C,D,K	B,C,D,K	B,C,D,K	B,C,D,K	B,C,D	B,C,D	B,C,D	B,C,D	B,C,D
		Icu	50	50	50	50	50	36	36	36	36	36	36
			In	25	32	40	50	63	25	32	40	50	63
		A	10	25	20				15				
		A	10	40	20	20	20		15	15	15		
		A	10	63	20	20	20	20	15	15	15	15	15
		A	10	25	20				15				
		A	10	40	20	20	20		15	15	15		
A	10	63	20	20	20	20	15	15	15	15	15		

## RCDs technical details

### Power loss, derating and performance in altitude

#### Power loss and internal resistance of RCDs and RCBOs

##### RCCBs F200 series

Rated current In [A]	Power loss per pole W	
	2P	4P
16	1.5	-
25	1.0	1.3
40	2.4	3.2
63	3.2	4.4
80	4.5	5.3
100	6.5	8.2
125	-	11.2

##### RCCBs F200 Type B

Power Loss [W]	In [A]	Per Pole	Total
F202 B	16	0.26	0.82
	25	0.65	1.6
	40	1.65	3.6
	63	4.14	8.58
F204 B	25	0.74	3.42
	40	1.92	6.96 (9.26)*
	63	4.8	15.6 (17.9)*
	80	5	15
	125	7.5 (11.2)**	33.6

\* 500 mA - \*\* 300 mA

##### RCD-Blocks DDA200 series

Rated current Ib [A]	Power loss Wlb* ①	
	2P	3P,4P
25	2.0	3.0
40	3.2	4.8
63	5.0	7.6

\* The power loss  $W_{lb}$  shown in the table refers to  $I_b$ . For use with circuit-breakers with lower rated current  $I_n$  the power loss  $W$  must be determined using the formula:  $W = (I_n / I_b) \cdot W_{lb}$

##### RCBOs DS 200, DS 200 M series

Rated current In [A]	Power loss W ①			
	Characteristic B-C		Characteristic K	
	2P	3P/4P	2P	3P/4P
6	4.1	6.2	3.9	5.9
10	2.9	4.4	2.9	4.2
13	5.2	7.7	3.1	4.5
16	4.5	6.6	4.9	7.2
20	6.4	9.3	6.8	9.9
25	8.5	12.4	7.9	11.5
32	10.9	15.7	10.7	15.4
40	15	21.6	14.4	20.7
50	11.4	18.4	10.7	17.4
63	17.4	28.2	18.2	29.4

##### RCD-Blocks DDA800

Rated current In [A]	Power loss Wlb* ①	
	2P	3P, 4P
63	9	13.5
100	7	10.5
125	-	16.6

\* The power loss  $W_{lb}$  shown in the table refers to  $I_b$ . For use with circuit-breakers with lower rated current  $I_n$  the power loss  $W$  must be determined using the formula:  $W = (I_n / I_b) \cdot W_{lb}$

##### RCBO DS201 - Voltage Drop, power loss, internal resistance, own consumption

Rated Current [A]	Total V drop [V]	Power loss for DS201 [W]			Total [mΩ]	
		Phase pole	Neutral pole	Average per pole		
1	1,4	1,4	0,0	0,7	1,4	1404,5
2	0,8	1,6	0,2	0,8	1,6	404,4
4	0,6	2,2	0,1	1,1	2,3	142,3
6	0,4	2,4	0,2	1,3	2,6	71,8
8	0,3	1,9	0,3	1,1	2,2	34,4
10	0,2	1,8	0,5	1,2	2,3	23,1
13	0,3	2,7	0,8	1,7	3,5	20,4
15	0,3	3,0	1,0	2,0	3,9	17,7
16	0,3	3,4	1,2	2,3	4,5	17,7
20	0,3	3,8	1,8	2,8	5,7	14,1
25	0,3	5,5	2,6	4,1	8,1	12,3
30	0,3	5,2	3,1	4,1	8,3	9,2
32	0,3	6,4	3,5	5,0	9,9	9,2
35	0,2	3,8	3,2	3,5	7,0	5,7
40	0,2	5,0	4,1	4,6	9,1	5,7

##### RCBOs DS202CR series

In	Power loss [W] ①	Internal resistance [mΩ]
6	3,0	84,4
10	3,3	32,8
13	3,8	22,5
15	3,9	16,4
16	4,2	16,4
20	5,0	12,6
25	6,2	9,9
32	7,6	7,4
40	8,9	5,6

##### RCBOs DS203NC series

In	Power loss [W] ①	Internal resistance [mΩ]
6A	7.5	207.3
8A	4.2	66.4
10A	5.6	55.9
13A	7.2	42.5
16A	10.0	39.3
20A	11.8	29.5
25A	10.3	16.4
32A	15.1	14.8

##### DS800P series ①

Rated current	Rated current		
In [A]	2P	3P	4P
125	25.7	45.7	55.1

① datas available in the tables are referred to the Power Loss per device

## RCDs technical details

### Power loss, derating and performance in altitude

#### RCBO DS301C - Voltage Drop, power loss, internal resistance, own consumption

##### Characteristic B

In (A)	Voltage drop (V)	Powerloss (W)				Internal Resistance (mΩ)
		Average per pole	Phase pole	Neutral pole	Total	
6 A	0.4	1.10	2.1	0.1	2.2	61.0
10 A	0.3	1.30	2.35	0.25	2.6	26.0
13 A	0.2	1.24	2.12	0.35	2.47	14.6
16 A	0.0	1.42	2.11	0.72	2.83	11.1
20 A	0.2	1.83	2.88	0.78	3.66	9.2

##### Characteristic C

6 A	0.3	0.78	1.47	0.09	1.56	43.3
10 A	0.2	0.75	1.25	0.25	1.5	15.0
13 A	0.2	1.13	1.95	0.3	2.25	13.3
16 A	0.2	1.24	1.84	0.65	2.48	9.7
20 A	0.2	1.70	2.6	0.8	3.4	8.5

##### RCBO DSE201 series

In [A]	Voltage drop [V]	Power loss [W]	Internal resistance [mΩ]
6	0.42	2.5	70
10	0.25	2.5	25
16	0.24	3.8	15
20	0.27	5.5	14
25	0.15	3.8	6.1
32	0.16	5.2	5
40	0.14	5.5	3.4
50	0.11	5.3	2.1

##### RCBO DSE201 M series

In [A]	Voltage drop [V]	Power loss [W]	Internal resistance [mΩ]
6	0.30	1.8	49
10	0.18	1.8	18
16	0.15	2.4	9.5
20	0.15	3.0	7.6
25	0.13	3.3	5.3
32	0.14	4.4	4.3
40	0.14	5.5	3.4
50	0.11	5.3	2.1

##### Power loss for DSE203 M / DSE203N M / DSE203NS M

In [A]	Power loss (W)		
	DSE203 M	DSE203N M	DSE203NS M
6	3.25	3.52	3.56
10	4.98	5.74	5.89
13	6.21	7.58	7.71
16	6.81	8.79	9.18
20	7.91	11.00	11.42
25	7.77	12.81	13.44
32	8.81	14.24	15.69
40	10.49	19.07	21.81
50	11.67	20.41	23.55
63	16.05	30.96	36.82

##### Power loss for DSN201E series

In [A]	Power Loss [W]
6	1.8
10	2.3
13	2.4
16	3.1
20	3.8
25	4.1
32	5.5

##### Power loss for DSE201 NS series

In [A]	Power Loss [W]
6	1.8
10	2.3
13	2.4
16	3.1
20	3.8
25	4.1
32	5.5

## RCDs technical details

### Power loss, derating and performance in altitude

#### Derating of load capability of RCBOs DS 200 series, DS201, DS202CR, DS203NC, DSE201 and DSE201 M

For DS 200 see tables for S 200 MCBs in technical details MCBs and dedicated tables for DS201 and DS202CR, within the range of temperatures from -25 °C to +55 °C.

#### Performance in altitude of RCDs

ABB RCDs are able to operate at altitude higher than foreseen by the relevant standard IEC/ EN 61008 and IEC/ EN 61009 taking into account the corrective factor below detailed:

Elevation	[m]	2000	3000	4000	5000	6000
Rated Current	[A]	1.0 x In	0.96 x In	0.94 x In	0.92 x In	0.90 x In
Rated Voltage	[V]	1.0 x Un	0.877 x Un	0.775 x Un	0.676 x Un	0.588 x Un

For altitude higher than 3.000 m the isolating characteristic is no longer available.

For DDA800 RCD Blocks according to IEC/EN 60947-2, up to 2000 meters above sea level, the rated characteristics remain unchanged.

With increasing altitude, the properties of the atmosphere change regarding composition, dielectricity, the cooling capacity and the pressure.

The characteristics of the DDA800 RCD Blocks therefore change: this can be measured for the most part using the change in significant parameters such as the maximum rated operational voltage and the rated current:

Elevation	[m]	2000	3000	4000	5000
Rated operational voltage Ue	[V]	690	600	540	470
Max rated current In	[A]	1x In	0.96 x In	0.93 x In	0.9 x In

## RCDs technical details

### Power loss, derating and performance in altitude

#### Derating in temperature for F200 series

Max operating current depending on the ambient temperature according to the standard IEC 61008-1.

Daily average ambient temperature is intended to be  $\leq +35$  °C.

In	Temperature (°C)											
	-25	-20	-10	0	10	20	30	40	45	50	55	60
16 A	16	16	16	16	16	16	16	16	16	16	16	15
25 A	25	25	25	25	25	25	25	25	25	25	25	24
40 A	40	40	40	40	40	40	40	40	40	40	40	37
63 A	63	63	63	63	63	63	63	63	60	56	51	46

#### Derating in temperature for DS301C series

Max operating current depending on the ambient temperature (daily average  $\leq 35$ °C) of characteristics type B and C.

In	Temperature (°C)											
	-25	-20	-10	0	10	20	30	40	50	55	60	70
6 A	8.3	7.8	7.3	7.0	6.7	6.3	6.0	6.0	5.9	5.8	5.7	5.7
10 A	13.8	13.5	12.7	12.1	11.0	10.4	10.0	9.5	9.2	9.0	8.9	8.8
13 A	17.8	17.1	16.5	15.8	14.8	13.9	13.0	12.4	12.2	12.0	11.9	11.8
16 A	20.6	19.9	19.0	18.4	17.7	16.6	16.0	15.4	15.0	14.8	14.6	14.5
20 A	25.8	24.8	23.5	22.9	21.9	20.8	20.0	19.4	18.7	18.2	18.0	17.9

#### Derating in temperature for DS203NC series

Max operating current depending on the ambient temperature of a circuit breaker in load circuit of characteristics type B, C, K.

Daily average ambient temperature is intended to be  $\leq +35$  °C.

B, C	Temperature (°C)										
	-25	-20	-10	0	10	20	30	40	55	70	
6A	7.29	7.16	6.91	6.65	6.41	6.17	6.00	5.90	5.75	6	
8A	9.71	9.54	9.20	8.85	8.55	8.24	8.00	7.83	7.57	6	
10A	12.13	11.92	11.49	11.06	10.68	10.31	10.00	9.76	9.39	8.5	
13A	15.77	15.49	14.93	14.37	13.89	13.41	13.00	12.65	12.12	11	
16A	19.40	19.06	18.37	17.68	17.10	16.52	16.00	15.54	14.5	13.8	
20A	23.66	23.32	22.63	21.94	21.26	20.57	20.00	19.53	18.84	17	
25A	29.00	28.65	27.96	27.27	26.46	25.65	25.00	24.53	23.83	21	
32A	38.67	38.13	37.04	35.96	34.48	33.00	32.00	31.47	29	27	

K	Temperature (°C)										
	-25	-20	-10	0	10	20	30	40	55	70	
6A	7.2	6.9	6.6	6.4	6.2	6.0	5.8	5.7	5.6	6	
8A	9.5	9.2	8.9	8.5	8.2	8.0	7.8	7.6	7.4	6	
10A	11.9	11.5	11.1	10.7	10.3	10.0	9.7	9.5	9.1	8.5	
13A	15.5	14.9	14.4	13.9	13.4	13.0	12.6	12.3	11.7	11	
16A	19.2	18.4	17.7	17.1	16.5	16.0	15.5	15.1	14.5	13.8	
20A	23.3	22.6	21.9	21.3	20.6	20.0	19.4	19.0	18.3	17	
25A	28.8	28.1	27.3	26.5	25.6	25.0	24.4	23.9	23.2	21	
32A	38.4	37.2	35.8	34.5	33.0	32.0	31.0	30.5	29	27	

## RCDs technical details

### Power loss, derating and performance in altitude

#### Derating in temperature for DS201 series

Max operating current depending on the ambient temperature of a circuit breaker in load circuit of characteristics type B, C. Daily average ambient temperature is intended to be  $\leq +35\text{ }^\circ\text{C}$ .

In (A)	Temperature ( $^\circ\text{C}$ )												
	-25	-20	-10	0	10	20	30	40	50	55	60	65	70
2A	3.9	3.6	3.2	2.9	2.7	2.4	2.0	1.8	1.7	1.6	1.5	1.4	1.3
4A	6.1	5.8	5.4	5.0	4.7	4.4	4.0	3.6	3.4	3.2	3.1	3.0	2.8
6A	8.7	8.4	7.7	7.3	7.0	6.4	6.0	5.5	5.3	5.1	4.9	4.7	4.6
8A	10.8	10.3	9.5	9.0	8.7	8.3	8.0	7.4	7.1	7.0	6.8	6.6	6.5
10A	13.5	13.0	12.1	11.5	11.0	10.6	10.0	9.4	9.0	8.8	8.6	8.4	8.3
13A	16.0	15.6	14.9	14.5	14.0	13.4	13.0	12.4	11.7	11.4	11.2	11.0	10.8
16A	18.9	18.6	18.1	17.5	17.0	16.4	16.0	15.3	14.8	14.5	14.3	14.1	14.0
20A	24.0	23.5	22.7	22.0	21.4	20.7	20.0	19.1	18.5	18.3	18.0	17.8	17.7
25A	27.9	27.5	27.1	26.6	26.0	25.3	25.0	24.3	23.6	23.4	23.2	23.0	22.8
32A	36.8	36.2	35.4	34.8	34.0	32.9	32.0	31.3	30.5	30.0	29.7	29.5	29.4
40A	44.8	44.6	44.0	43.2	42.1	41.0	40.0	39.0	38.1	37.9	37.6	37.4	37.2

Max operating current depending on the ambient temperature of a circuit breaker in load circuit of characteristics type K. Daily average ambient temperature is intended to be  $\leq +35\text{ }^\circ\text{C}$ .

In (A)	Temperature ( $^\circ\text{C}$ )												
	-25	-20	-10	0	10	20	30	40	50	55	60	65	70
1A	2.2	2.2	1.7	1.5	1.3	1.0	0.7	0.6	0.6	0.5	0.5	0.4	0.4
2A	3.5	3.2	2.8	2.8	2.4	2.0	1.8	1.8	1.7	1.6	1.5	1.5	1.4
4A	5.7	5.3	4.9	4.8	4.4	4.0	3.6	3.4	3.3	3.0	2.9	2.8	2.8
6A	8.0	7.7	7.4	7.0	6.5	6.0	5.4	5.3	5.2	4.8	4.7	4.6	4.5
8A	10.0	9.5	9.0	8.7	8.2	8.0	7.4	7.1	7.0	6.7	6.6	6.5	6.4
10A	12.6	12.1	11.5	11.0	10.5	10.0	9.4	9.1	8.9	8.8	8.6	8.4	8.3
13A	15.4	14.9	14.4	14.1	13.4	13.0	12.5	11.8	11.4	11.2	11.0	10.8	10.7
16A	18.7	18.2	17.5	17.0	16.4	16.0	15.4	14.7	14.6	14.3	14.2	14.0	13.9
20A	23.1	22.7	22.1	21.3	20.7	20.0	19.1	18.5	18.2	18.1	17.9	17.8	17.7
25A	27.4	27.1	26.5	26.0	25.4	25.0	24.3	23.6	23.4	23.2	23.0	22.8	22.6
32A	36.1	35.4	34.9	34.0	32.8	32.0	31.2	30.5	29.9	29.7	29.5	29.4	29.3
40A	44.4	43.9	43.2	42.1	40.9	40.0	39.0	38.2	37.7	37.4	37.2	37.0	36.8

#### Derating in temperature for DS202CR series

Max. operating current depending on the ambient temperature of a circuit-breaker in load circuit of characteristics type B and C. Daily average ambient temperature is intended to be  $\leq +35\text{ }^\circ\text{C}$ .

B, C In (A)	Temperature ( $^\circ\text{C}$ )								
	0	10	20	25	30	40	50	60	
6	7,2	6,8	6,4	6,2	6,0	5,5	5,1	4,5	
10	12,2	11,5	10,8	10,4	10,0	9,1	8,2	7,1	
13	15,7	14,8	13,9	13,5	13,0	12,0	10,9	9,6	
16	19,1	18,2	17,1	16,6	16,0	14,8	13,4	11,9	
20	24,0	22,8	21,4	20,7	20,0	18,4	16,6	14,5	
25	30,2	28,6	26,9	26,0	25,0	22,9	20,6	18,0	
32	37,6	35,9	34,0	33,0	32,0	29,9	27,5	25,0	
40	46,5	44,4	42,3	41,2	40,0	37,5	34,9	31,9	

## RCDs technical details

### Power loss, derating and performance in altitude

#### Derating in temperature for DSE201 series

Max operating current depending on the ambient temperature of a circuit breaker in load circuit of characteristics type B, C. Daily average ambient temperature is intended to be  $\leq +35$  °C.

In	Temperature (°C)									
	-25	-20	-10	0	10	20	30	40	50	55
6 A	8.1	8.0	7.8	7.4	6.9	6.5	6.0	5.9	5.8	5.7
10 A	13.8	13.5	13.0	12.3	11.6	10.8	10.0	9.9	9.7	9.7
16 A	19.7	19.5	19.1	18.5	17.6	16.6	16.0	15.8	15.5	15.4
20 A	23.7	23.5	23.2	22.7	21.6	20.5	20.0	19.7	19.4	19.2
25 A	30.2	29.2	29.2	28.4	27.0	25.7	25.0	24.6	24.1	23.9
32 A	39.4	37.7	37.7	36.4	34.7	33.0	32.0	31.4	30.7	30.4
40 A	50.3	47.9	47.9	45.6	43.6	41.5	40.0	39.0	38.4	38.1
50 A	61.1	59.2	59.2	57.1	54.4	51.7	50.0	48.8	48.0	47.9

#### Derating in temperature for DSE201 M series

Max operating current depending on the ambient temperature of a circuit breaker in load circuit of characteristics type B, C. Daily average ambient temperature is intended to be  $\leq +35$  °C.

In	Temperature (°C)									
	-25	-20	-10	0	10	20	30	40	50	55
6 A	7.3	7.2	6.9	6.7	6.4	6.2	6.0	5.9	5.9	5.8
10 A	13.0	12.9	12.2	11.4	10.9	10.4	10.0	9.8	9.7	9.5
16 A	20.2	19.7	18.7	17.8	17.3	16.6	16.0	15.8	15.4	15.2
20 A	26.0	19.7	24.0	22.8	21.9	20.7	20.0	19.8	19.6	19.5
25 A	32.6	25.2	30.4	29.0	27.5	26.0	25.0	24.6	24.2	23.9
32 A	41.1	31.5	38.0	36.3	34.8	33.1	32.0	30.9	29.8	29.6
40 A	50.3	49.4	47.9	45.6	43.7	41.5	40.0	39.0	38.4	38.1
50 A	61.1	60.4	59.2	57.1	54.4	51.7	50.0	48.8	48.0	47.9

#### Derating in temperature for F200 B series

Max operating current depending on the ambient temperature of the residual current circuit breaker.

In	Temperature (°C)				
	-25...50	55	60	65	70
16 A	16	16	16	16	16
25 A	25	25	25	25	25
40 A	40	40	40	40	32
63 A	63	55	48	40	32

## RCDs technical details

### Power loss, derating and performance in altitude

#### Derating in temperature for DSN201E series

Max operating current depending on the ambient temperature of a circuit breaker in load circuit of characteristics type B and C. Daily average ambient temperature is intended to be  $\leq +35\text{ }^{\circ}\text{C}$ .

In [A]	Temperature [ $^{\circ}\text{C}$ ]																	
	-25	-20	-15	-10	-5	0	5	10	15	20	25	30	35	40	45	50	55	
6	6.9	6.8	6.7	6.6	6.6	6.5	6.4	6.3	6.2	6.2	6.1	6.0	5.9	5.8	5.8	5.7	5.6	
10	11.4	11.3	11.1	11.0	10.9	10.8	10.6	10.5	10.4	10.3	10.1	10.0	9.9	9.7	9.6	9.5	9.4	
13	14.9	14.7	14.6	14.4	14.2	14.0	13.9	13.7	13.5	13.3	13.2	13.0	12.8	12.7	12.5	12.3	12.1	
16	18.3	18.1	17.9	17.7	17.5	17.3	17.1	16.8	16.6	16.4	16.2	16.0	15.8	15.6	15.4	15.2	14.9	
20	23.3	23.0	22.7	22.4	22.1	21.8	21.5	21.2	20.9	20.6	20.3	20.0	19.7	19.4	19.1	18.8	18.5	
25	29.7	29.2	28.8	28.4	28.0	27.5	27.1	26.7	26.3	25.8	25.4	25.0	24.6	24.2	23.7	23.3	22.9	
32	38.6	38.0	37.4	36.8	36.2	35.6	35.0	34.4	33.8	33.2	32.6	32.0	31.4	30.8	30.2	29.6	29.0	

#### Derating in temperature for DSE201 NS series

Max operating current depending on the ambient temperature of a circuit breaker in load circuit of characteristics type B and C. Daily average ambient temperature is intended to be  $\leq +35\text{ }^{\circ}\text{C}$ .

In [A]	Temperature [ $^{\circ}\text{C}$ ]																	
	-25	-20	-15	-10	-5	0	5	10	15	20	25	30	35	40	45	50	55	
6	6.9	6.8	6.7	6.6	6.6	6.5	6.4	6.3	6.2	6.2	6.1	6.0	5.9	5.8	5.8	5.7	5.6	
10	11.4	11.3	11.1	11.0	10.9	10.8	10.6	10.5	10.4	10.3	10.1	10.0	9.9	9.7	9.6	9.5	9.4	
13	14.9	14.7	14.6	14.4	14.2	14.0	13.9	13.7	13.5	13.3	13.2	13.0	12.8	12.7	12.5	12.3	12.1	
16	18.3	18.1	17.9	17.7	17.5	17.3	17.1	16.8	16.6	16.4	16.2	16.0	15.8	15.6	15.4	15.2	14.9	
20	23.3	23.0	22.7	22.4	22.1	21.8	21.5	21.2	20.9	20.6	20.3	20.0	19.7	19.4	19.1	18.8	18.5	
25	29.7	29.2	28.8	28.4	28.0	27.5	27.1	26.7	26.3	25.8	25.4	25.0	24.6	24.2	23.7	23.3	22.9	
32	38.6	38.0	37.4	36.8	36.2	35.6	35.0	34.4	33.8	33.2	32.6	32.0	31.4	30.8	30.2	29.6	29.0	

#### Derating in temperature for DSE203 M / DSE203N M / DSE203NS M

Max operating current depending on the ambient temperature of a circuit breaker in load circuit of characteristics type B, C, D. Daily average ambient temperature is intended to be  $\leq +35\text{ }^{\circ}\text{C}$ .

In [A]	Temperature ( $^{\circ}\text{C}$ )												
	-5	0	5	10	15	20	25	30	35	40	45	50	55
6	7.1	6.9	6.8	6.7	6.5	6.3	6.2	6.0	5.8	5.6	5.5	5.3	5.1
10	11.2	11.0	10.9	10.7	10.5	10.4	10.2	10.0	9.8	9.6	9.5	9.2	9.1
13	14.8	14.6	14.3	14.0	13.7	13.5	13.2	13.0	12.5	12.5	12.2	12.0	11.7
16	18.3	18.0	17.7	17.3	17.1	16.6	16.3	16.0	15.7	15.3	14.9	14.5	14.2
20	23.0	22.5	22.1	21.7	21.3	20.9	20.4	20.0	19.6	19.1	18.7	18.1	17.6
25	28.0	27.6	27.2	26.8	26.3	26.0	25.5	25.0	24.6	24.1	23.5	23.2	22.7
32	36.7	36.0	35.4	34.8	34.2	33.5	32.7	32.0	31.3	30.6	29.8	29.0	28.1
40	45.2	44.6	43.8	43.1	42.3	41.6	40.8	40.0	39.2	38.4	37.5	36.7	35.7
50	56.2	55.4	54.6	53.7	52.9	51.8	50.9	50.0	49.0	48.1	47.0	45.9	45.0
63	71.2	70.1	68.9	67.8	66.6	65.3	64.2	63.0	61.8	60.5	58.7	57.3	55.9

# RCDs technical details

## Tripping characteristic

### Tripping characteristics valid for all the RCBOs

Acc. to	Tripping characteristic and rated current	Thermal release ②		Tripping time	Electromagnetic release ①		Tripping time
		Current: conventional non-tripping current	conventional tripping current		Currents: hold current surges	trip at least at	
IEC/EN 60898-1	B	6 to 40 A	$1.13 \cdot I_n$	$> 1 \text{ h}$	$3 \cdot I_n$	$> 0.1 \text{ s}$	
	C	2 to 40 A	$1.13 \cdot I_n$	$< 1 \text{ h}$	$5 \cdot I_n$	$< 0.1 \text{ s}$	
IEC/EN 60947-2	K	1 to 40 A	$1.05 \cdot I_n$	$> 1 \text{ h}$	$10 \cdot I_n$	$> 0.2 \text{ s}$	
			$1.2 \cdot I_n$	$< 1 \text{ h}$ ③	$14 \cdot I_n$	$< 0.2 \text{ s}$	
			$1.5 \cdot I_n$	$< 2 \text{ min.}$ ③			
			$6.0 \cdot I_n$	$> 2 \text{ s (T1)}$			

① The indicated electromagnetic tripping values apply to a frequency range of 16 2/3 ... 60 Hz. For different network frequencies or direct current the values change according to the multiplier in the table below.

② The thermal releases are calibrated to a nominal reference ambient temperature; for Z and K, the value is 20 °C, for B and C = 30 °C.

In the case of higher ambient temperatures, the current values fall by ca. 6 % for each 10 K temperature rise.

③ As from operating temperature (after  $I_1 > 1 \text{ h}$  or, as applicable, 2 h).

### Characteristic B

IEC/EN 61009-1

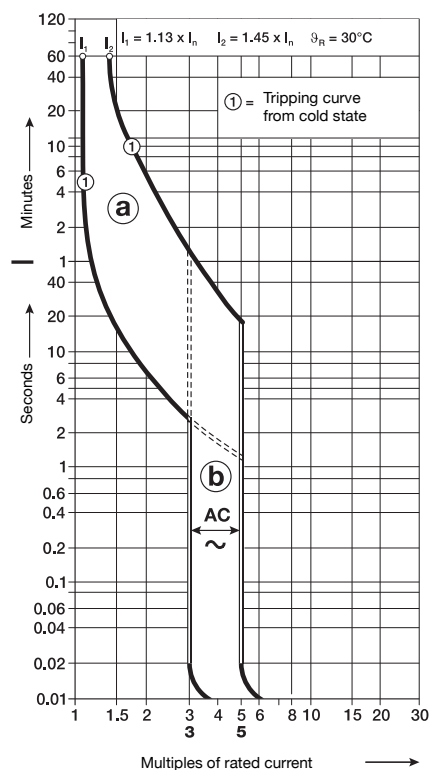

### Characteristic C

IEC/EN 61009-1

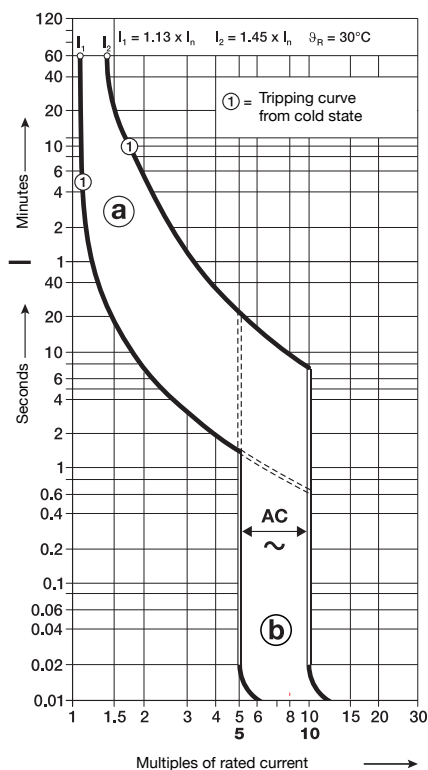

### Characteristic K

IEC-EN60947-2

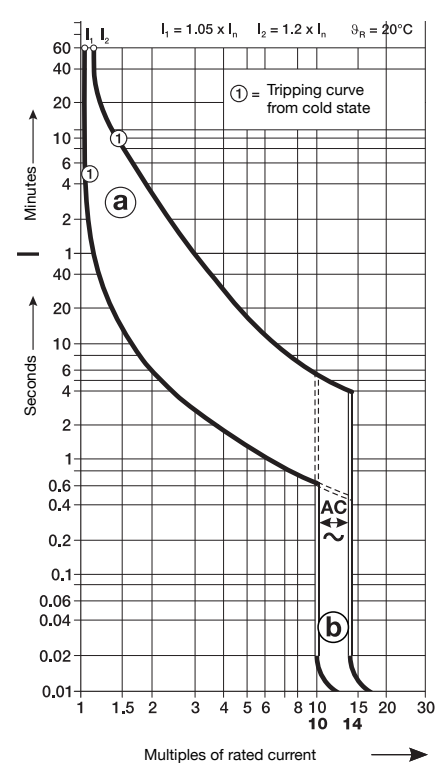

Ⓐ thermal trip

Ⓑ electromagnetic trip

## RCDs technical details

### Emergency stop using DDA 200 AE series

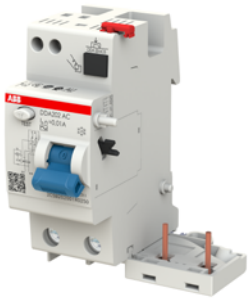

#### RCD-blocks type AE

#### Emergency stop using DDA 200 AE series RCD-blocks

The AE series RCD-block combines the protection supplied by the RCBOs with a positive safety emergency stop function for remote tripping.

In the AE version, the DDA 200 AE series RCD-blocks are available.

#### Operating principle (patented)

Two additional primary circuits powered with the same voltage and equipped with the same resistance have been added to the transformer; under normal conditions the same current would flow through, but since they are wound by the same number of coils in opposite directions they cancel each other out and do not produce any flow.

One of these two windings acts as the remote control circuit: the emergency stop is obtained by interrupting the current flow in this circuit.

The positive safety is therefore obvious: an accidental breakage in the circuit is equivalent to operating an emergency control button.

#### Advantages

Compared with the devices which are normally used in emergency circuits, DDA 200 AE blocks have the following advantages:

- positive safety
- no unwanted tripping if there is a temporary reduction or interruption of the mains voltage
- efficient immediate operation even after long off-service periods of the installation

#### Use

Application of the DDA 200 AE blocks complies with the requirements of IEC 60364-8. They are therefore suitable, for example, for escalators, lifts, hoists, electrically operated gates, machine tools, car washes and conveyor belts.

No more than one DDA 200 AE can be controlled using the same control circuit. Each DDA 200 AE requires a dedicated control circuit.

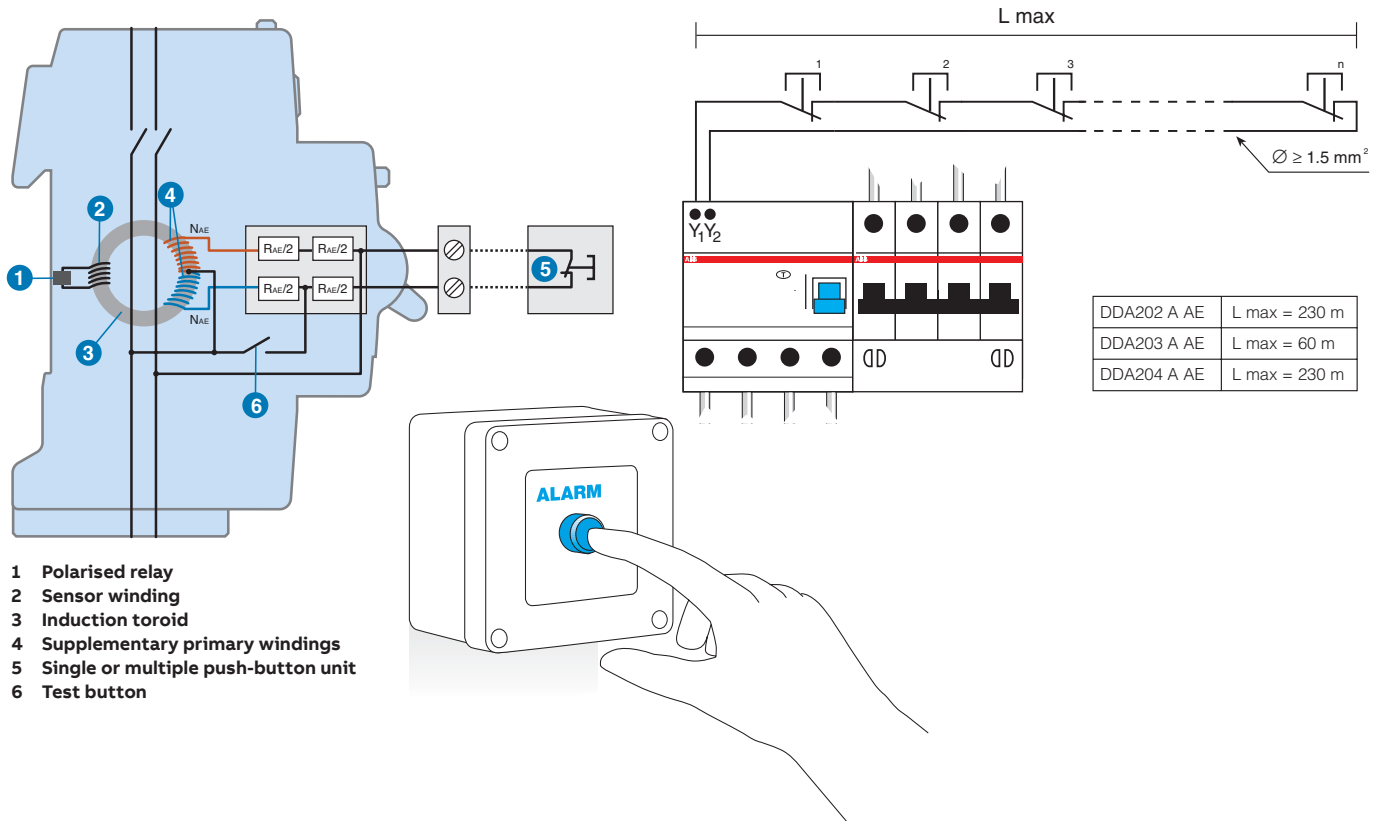

## RCDs technical details

### Terminal capacity for F200, DS201 and DS203NC

#### Rigid cable

Stripping length 10...12mm, max terminal capacity

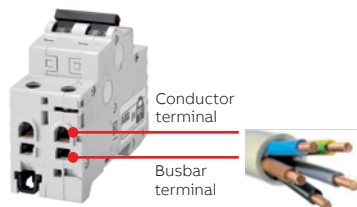

Conductor terminal			Busbar terminal			
2	x	0,75 mm <sup>2</sup>	2	x	0,75 mm <sup>2</sup>	or busbar
2	x	1 mm <sup>2</sup>	2	x	1 mm <sup>2</sup>	or busbar
2	x	1,5 mm <sup>2</sup>	2	x	1,5 mm <sup>2</sup>	or busbar
2	x	2,5 mm <sup>2</sup>	2	x	2,5 mm <sup>2</sup>	or busbar
2	x	4 mm <sup>2</sup>	2	x	4 mm <sup>2</sup>	or busbar
2	x	6 mm <sup>2</sup>	1	x	6 mm <sup>2</sup>	or busbar
2	x	10 mm <sup>2</sup>	1	x	10 mm <sup>2</sup>	or busbar
1	x	16 mm <sup>2</sup>				busbar
1	x	25 mm <sup>2</sup>				busbar

#### Flexible cable

Stripping length 10...12mm, max terminal capacity

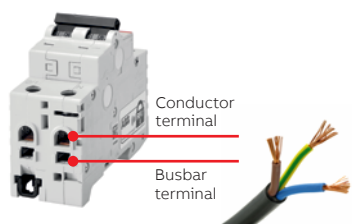

Conductor terminal			Busbar terminal			
2	x	0,75 mm <sup>2</sup>	2	x	0,75 mm <sup>2</sup>	or busbar
2	x	1 mm <sup>2</sup>	2	x	1 mm <sup>2</sup>	or busbar
2	x	1,5 mm <sup>2</sup>	2	x	1,5 mm <sup>2</sup>	or busbar
2	x	2,5 mm <sup>2</sup>	2	x	2,5 mm <sup>2</sup>	or busbar
2	x	4 mm <sup>2</sup>	2	x	4 mm <sup>2</sup>	or busbar
2	x	6 mm <sup>2</sup>	1	x	6 mm <sup>2</sup>	or busbar
2	x	10 mm <sup>2</sup>				busbar
1	x	16 mm <sup>2</sup>				busbar

#### Flexible cable with ferrule with collar

Stripping length 10...12mm, max terminal capacity<sup>1</sup>

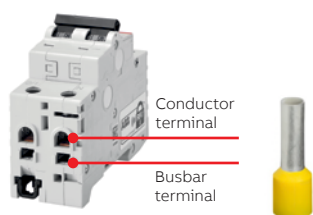

Conductor terminal			Busbar terminal			
2	x	0,75 mm <sup>2</sup>	2	x	0,75 mm <sup>2</sup>	or busbar
2	x	1 mm <sup>2</sup>	2	x	1 mm <sup>2</sup>	or busbar
2	x	1,5 mm <sup>2</sup>	2	x	1,5 mm <sup>2</sup>	or busbar
2	x	2,5 mm <sup>2</sup>	2	x	2,5 mm <sup>2</sup>	or busbar
2	x	4 mm <sup>2</sup>	2	x	4 mm <sup>2</sup>	or busbar
2	x	6 mm <sup>2</sup>	1	x	6 mm <sup>2</sup>	or busbar
2	x	10 mm <sup>2</sup>	1	x	10 mm <sup>2</sup>	or busbar
1	x	16 mm <sup>2</sup>				busbar

#### Flexible cable with twin ferrules with collar

Stripping length 10...12mm, max terminal capacity<sup>1</sup>

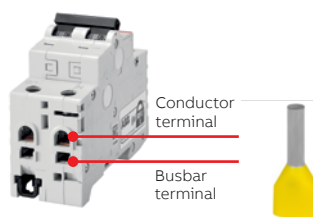

Conductor terminal			Busbar terminal			
(2)	x	0,75 mm <sup>2</sup>	(2)	x	0,75 mm <sup>2</sup>	or busbar
(2)	x	1 mm <sup>2</sup>	(2)	x	1 mm <sup>2</sup>	or busbar
(2)	x	1,5 mm <sup>2</sup>	(2)	x	1,5 mm <sup>2</sup>	or busbar
(2)	x	2,5 mm <sup>2</sup>	(2)	x	2,5 mm <sup>2</sup>	or busbar
(2)	x	4 mm <sup>2</sup>	(2)	x	4 mm <sup>2</sup>	or busbar
(2)	x	6 mm <sup>2</sup>	(2)	x	6 mm <sup>2</sup>	or busbar
(2)	x	10 mm <sup>2</sup>				busbar

(2) means two conductors in one twin ferrules

<sup>1</sup> The execution of the crimpage must be done according to crimpage tool manufacturer instruction. E.g. ABB crimpage tool FER9500, FER9501 and ERG4.

## RCDs technical details

### Terminal capacity for DDA200

#### rigid cable

Stripping length 10...12mm, max terminal capacity

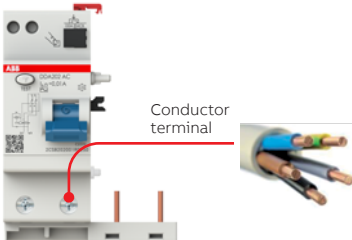

Conductor terminal		
2	x	0,75 mm <sup>2</sup>
2	x	1 mm <sup>2</sup>
2	x	1,5 mm <sup>2</sup>
2	x	2,5 mm <sup>2</sup>
1	x	4 mm <sup>2</sup>
1	x	6 mm <sup>2</sup>
1	x	10 mm <sup>2</sup>

#### flexible cable

Stripping length 10...12mm, max terminal capacity

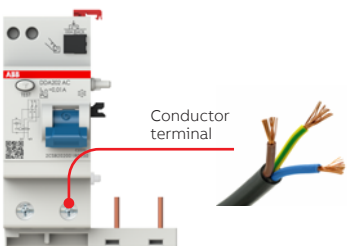

Conductor terminal		
2	x	0,75 mm <sup>2</sup>
2	x	1 mm <sup>2</sup>
2	x	1,5 mm <sup>2</sup>
2	x	2,5 mm <sup>2</sup>
2	x	4 mm <sup>2</sup>
1	x	6 mm <sup>2</sup>
1	x	10 mm <sup>2</sup>

#### flexible cable with ferrule with collar

Stripping length 10...12mm, max terminal capacity<sup>1</sup>

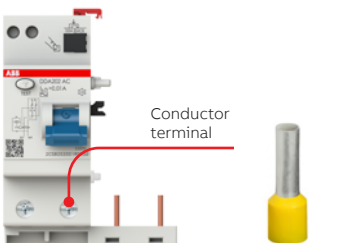

Conductor terminal		
2	x	0,75 mm <sup>2</sup>
2	x	1 mm <sup>2</sup>
2	x	1,5 mm <sup>2</sup>
2	x	2,5 mm <sup>2</sup>
2	x	4 mm <sup>2</sup>
1	x	6 mm <sup>2</sup>
1	x	10 mm <sup>2</sup>

#### flexible cable with twin ferrules with collar

Stripping length 10...12mm, max terminal capacity<sup>1</sup>

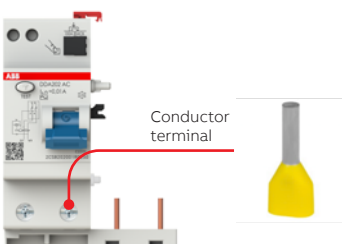

Conductor terminal		
(2)	x	0,75 mm <sup>2</sup>
(2)	x	1 mm <sup>2</sup>
(2)	x	1,5 mm <sup>2</sup>
(2)	x	2,5 mm <sup>2</sup>
(2)	x	4 mm <sup>2</sup>

(2) means two conductors in one twin ferrules

<sup>1</sup> The execution of the crimpage must be done according to crimpage tool manufacturer instruction. E.g. ABB crimpage tool FER9500, FER9501 and ERG4

## RCDs technical details

### Terminal capacity for DSE201 NS

#### Rigid cable

Max terminal capacity



#### BOTTOM Conductor terminal

2	x	1 mm <sup>2</sup>
2	x	1,5 mm <sup>2</sup>
2	x	2,5 mm <sup>2</sup>
2	x	4 mm <sup>2</sup>
2	x	6 mm <sup>2</sup>
2	x	10 mm <sup>2</sup>
2	x	16 mm <sup>2</sup>
1	x	25 mm <sup>2</sup>
1	x	35 mm <sup>2</sup>

#### TOP Conductor terminal

2	x	1 mm <sup>2</sup>
2	x	1,5 mm <sup>2</sup>
2	x	2,5 mm <sup>2</sup>
2	x	4 mm <sup>2</sup>
2	x	6 mm <sup>2</sup>
2	x	10 mm <sup>2</sup>
1	x	16 mm <sup>2</sup>
1	x	25 mm <sup>2</sup>

#### Flexible cable

Max terminal capacity



#### BOTTOM Conductor terminal

2	x	1 mm <sup>2</sup>
2	x	1,5 mm <sup>2</sup>
2	x	2,5 mm <sup>2</sup>
2	x	4 mm <sup>2</sup>
2	x	6 mm <sup>2</sup>
2	x	10 mm <sup>2</sup>
1	x	16 mm <sup>2</sup>
1	x	25 mm <sup>2</sup>

#### TOP Conductor terminal

2	x	1 mm <sup>2</sup>
2	x	1,5 mm <sup>2</sup>
2	x	2,5 mm <sup>2</sup>
2	x	4 mm <sup>2</sup>
2	x	6 mm <sup>2</sup>
2	x	10 mm <sup>2</sup>
1	x	16 mm <sup>2</sup>

#### Flexible cable with ferrule without collar

Max terminal capacity



#### BOTTOM Conductor terminal

2	x	1 mm <sup>2</sup>
2	x	1,5 mm <sup>2</sup>
2	x	2,5 mm <sup>2</sup>
2	x	4 mm <sup>2</sup>
2	x	6 mm <sup>2</sup>
2	x	10 mm <sup>2</sup>
1	x	16 mm <sup>2</sup>
1	x	25 mm <sup>2</sup>

#### TOP Conductor terminal

2	x	1 mm <sup>2</sup>
2	x	1,5 mm <sup>2</sup>
2	x	2,5 mm <sup>2</sup>
2	x	4 mm <sup>2</sup>
2	x	6 mm <sup>2</sup>
2	x	10 mm <sup>2</sup>
1	x	16 mm <sup>2</sup>

## RCDs technical details

### Terminal capacity for DSN201E

#### Rigid cable

Max terminal capacity



Conductor terminal		
2	x	1 mm <sup>2</sup>
2	x	1,5 mm <sup>2</sup>
2	x	2,5 mm <sup>2</sup>
2	x	4 mm <sup>2</sup>
2	x	6 mm <sup>2</sup>
2	x	10 mm <sup>2</sup>
1	x	16 mm <sup>2</sup>
1	x	25 mm <sup>2</sup>

#### Flexible cable

Max terminal capacity



Conductor terminal		
2	x	1 mm <sup>2</sup>
2	x	1,5 mm <sup>2</sup>
2	x	2,5 mm <sup>2</sup>
2	x	4 mm <sup>2</sup>
2	x	6 mm <sup>2</sup>
2	x	10 mm <sup>2</sup>
1	x	16 mm <sup>2</sup>

#### Flexible cable with ferrule without collar

Max terminal capacity



Conductor terminal		
2	x	1 mm <sup>2</sup>
2	x	1,5 mm <sup>2</sup>
2	x	2,5 mm <sup>2</sup>
2	x	4 mm <sup>2</sup>
2	x	6 mm <sup>2</sup>
2	x	10 mm <sup>2</sup>
1	x	16 mm <sup>2</sup>

## RCDs technical details

### Unwanted tripping - AP-R solution (high immunity)

#### Unwanted tripping

In the event of disturbance in the mains, the RCDs normally present in the system are tripped, breaking the circuit even in the absence of a true earth fault.

Disturbances of this kind are most often caused by:

- operation overvoltages caused by inserting or removing loads (opening or closing protection of control devices, starting and stopping motors, switching fluorescent lighting systems on and off, etc.)
- overvoltages of atmospheric origin, caused by direct or indirect discharges on the electrical line.

Under these circumstances, breaker tripping is unwanted, since it does not satisfy the need to avoid the risks due to direct and indirect contacts. On the contrary, the sudden and unjustified interruption of the power supply may result in very serious problems.

#### AP-R RCDs

The ABB range of AP-R anti-disturbance residual current circuit-breakers and blocks was designed to overcome the problem of unwanted tripping due to overvoltages of atmospheric or operation origin.

The electronic circuit in these devices can distinguish between temporary leakage caused by disturbances on the mains and permanent leakage due to actual faults, only breaking the circuit in the latter case.

AP-R residual current circuit-breakers and blocks have a slight delay into the tripping time, but this does not compromise the safety limits set by the Standards in force (release time at  $2 I\Delta n=150$  ms).

Guaranteeing conventional residual current protection, their installation in the electrical circuit therefore allows any unwanted tripping to be avoided in domestic and industrial systems in which service continuity is essential.

This delay makes the AP-R residual current devices especially suited for installations involving motor starters/variable speed drives, fluorescent lamps or IT/electronic equipment.

The use of multiple electronic reactors for the supply of fluorescent lamps instead generates permanent leakage currents and inrush currents that can cause nuisance tripping of a standard residual current circuit breaker. IT system loads and other electronic equipment (e.g. dimmers, computers, inverters) with capacitive input filters connected between the phases and ground can also generate permanent earth leakage currents whose sum may provoke the nuisance tripping of a standard residual current circuit breaker. For these situations, the AP-R breakers allow a greater number of devices to be connected to the installation.

Frequency converters include a rectifier section and an inverter section.

In case of fault within a single-phase frequency converter AP-R type RCDs provide complete protection, because an earth fault occurring downstream the inverter, produces an earth fault current with multi-frequency shape with high amount of harmonics.

While, in case of fault within a three-phase frequency converter, B type RCDs ensure complete protection because in case of insulation fault between the rectifier and the inverter or downstream the inverter we can have a smooth DC earth fault current.

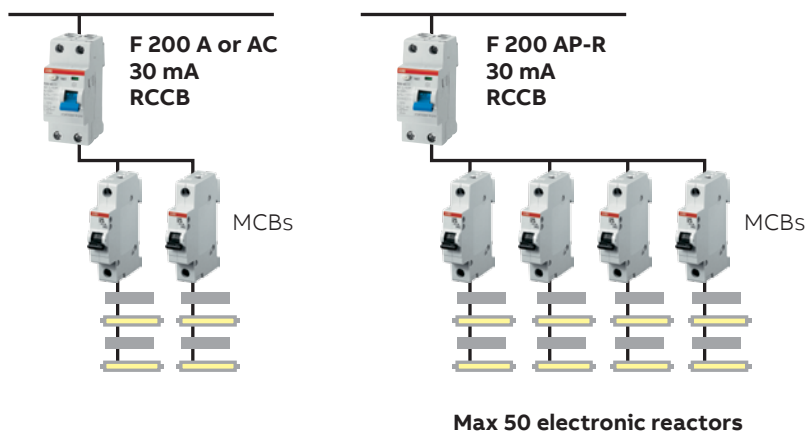

## RCDs technical details

### Unwanted tripping - AP-R solution (high immunity)

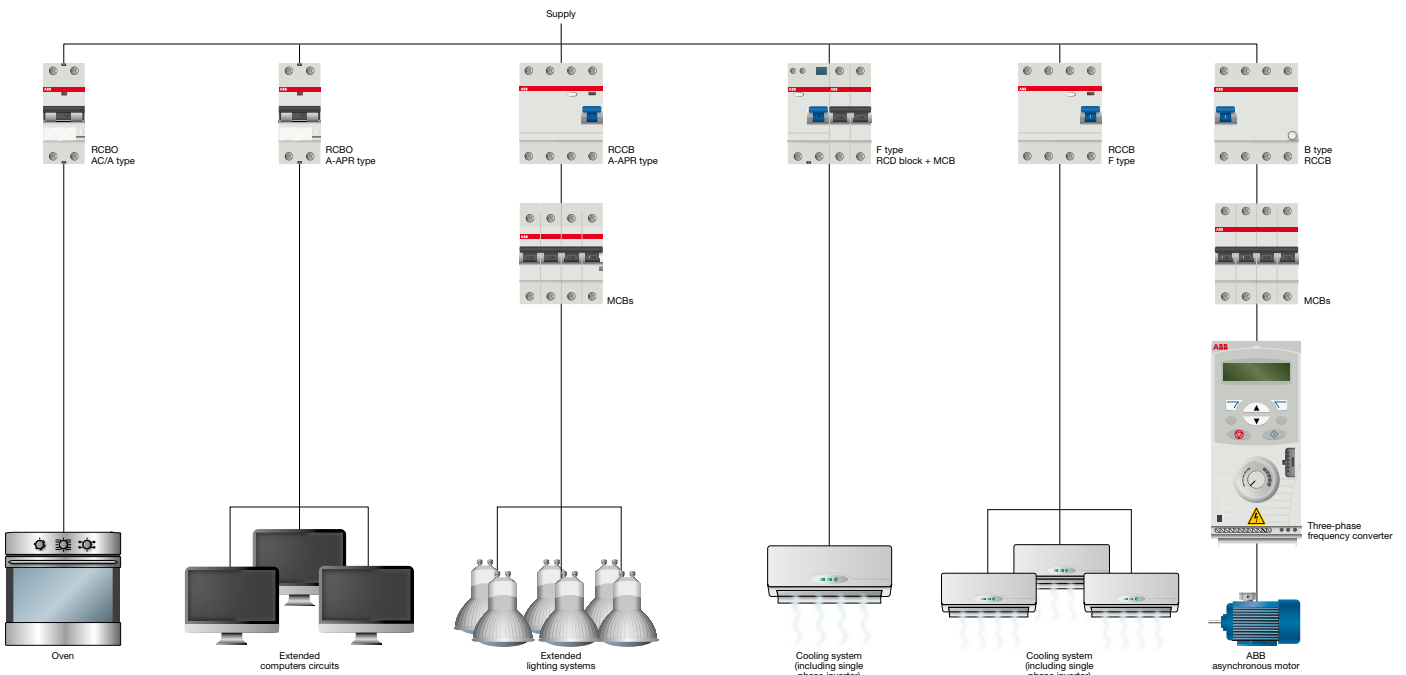

Compared with standard type breakers, AP-R residual current breakers are therefore characterised, for any given sensibility, by:

- Higher residual trip current
- Tripping time delay
- Better resistance to overvoltages, harmonics and impulse disturbances.

#### Regulations

The tests set out in the IEC 61008 and IEC 61009 standards verify the resistance of residual current breakers to unwanted tripping provoked by operation overvoltages, using a ring wave impulse shape of 0.5  $\mu$ s/100 kHz. All

residual current circuit-breakers are required to pass this test with a peak current value of 200 A.

For what concerns atmospheric overvoltages, the IEC 61008 and 61009 standards prescribe the 8/20  $\mu$ s surge test with a 3000 A peak current, but limit the requirement to residual current devices classified as selective; no test is required for other types.

The ABB range of AP-R anti- nuisance tripping breakers and blocks pass the general 0.5  $\mu$ s/100 kHz ring wave test and also withstand the 8/20  $\mu$ s impulse test with the same peak current of 3000 A prescribed for selective devices.

	A or AC	AP-R	B	Selective
Resistance to unwanted tripping caused by network disturbances with wave shape (0.5 $\mu$ s/100 kHz)	250	250	200	250
Resistance to nuisance tripping due to overvoltages (operational or atmospheric) peak (8/20 wave)	N.A.	3000	3000	5000

## RCDs technical details

### Unwanted tripping - F2C-ARH solution

The F2C-ARH is an auto-reclosing device particularly suited for household and similar uses. It doesn't require a separate low voltage power supply, and can be supplied by the associated RCCBs (2 pole RCCBs up to 63 A – 30 mA) at the 230 V a.c. rated voltage.

Another feature that makes the product ideal for home applications is an internal control unit that checks there are

no insulation faults in the system before allowing the RCCB to reclose.

This ensures that reclosing occurs only in case of unwanted tripping of the RCCB (i.e. overvoltages induced by electrical storms), thus assuring continuity of power supply also in these situations.

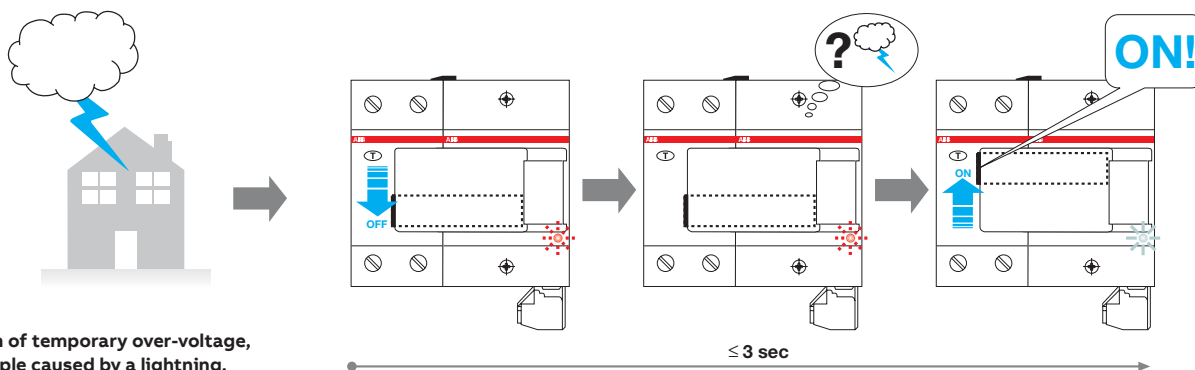

When the RCCB operates in presence of an effective insulation fault, the auto-reclosing device doesn't allow its reclosing and guarantees the system insulation.

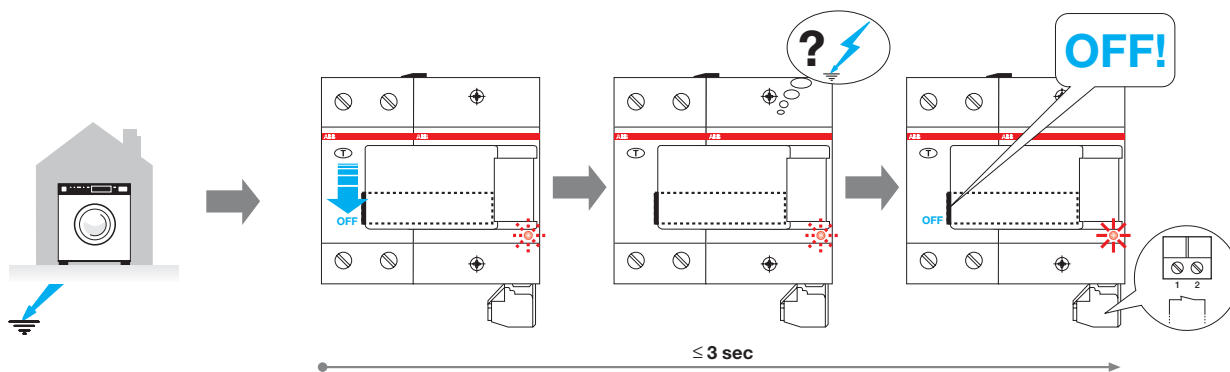

## RCDs technical details

### Type B RCDs

#### Type B RCDs

In industrial electrical applications it is more and more common to use devices where in the event of an earth fault current unidirectional direct currents or currents with a minimum residual ripple which flow through the PE conductor can emerge. These devices can be for example inverters, medical equipment (e.g. x-ray equipment and CAT), or UPS.

Type A RCDs sensitive to pulsating currents (in addition to sinusoidal currents detected by RCDs of type AC as well) cannot detect and break these earth fault direct currents or currents with a minimum level residual ripple. In case there are electrical appliances which generate this type of currents in the event of an earth fault the use of RCDs of type AC or type A would not be appropriate.

In addition to Type A RCDs, Type F RCDs with an intermediate characteristics are also tested according to IEC/EN 62423 which foresees the application of a simulated multi-frequency residual current with appropriate coefficient associated to the each level of frequency up to 1kHz. A single phase frequency converter, also named as inverter, is a commonly used electric drive which regulates the speed of an electric motor, operating on supply voltage and frequency.

During normal operation, the current generated by a single phase inverter in the downstream section is the result of the overlapping of mixed frequency components which varies from 10Hz (motor frequency), to 50Hz (rated frequency) and 1000Hz (switching frequency).

RCDs type F have been specifically designed for single phase inverters applications in order to meet the requirement to assure adequate protection level in case of an earth fault with such harmonic content, offering at the same time an increased resistance to nuisance tripping.

On the other side only RCD type B remain the only devices which are suitable to detect smooth DC components in the residual current caused by insulation faults in the DC section of a three phase frequency converter

Standard IEC 62423 specifies requirements and tests for type B RCDs (RCCBs and/or RCBOs) for household and similar uses. Requirements and tests given in this standard are in addition to the requirements of type A given in IEC 61008 (for RCCBs) or IEC 61009 (for RCBOs, including RCD-blocks). This means that RCDs of type B have to be compliant also to all the requirements of residual current devices of type A.

As already said, type B RCDs are not only sensitive to alternating and pulsating earth fault currents with DC components at a frequency of 50/60 Hz (type A), but they are also sensitive to:

- alternating currents up to a frequency of 1000 Hz;
- alternating and/or pulsating currents with DC components overlapping with a direct current;
- earth fault currents generated by a rectifier with two or more phases;
- direct earth fault currents without residual ripple

Type B RCDs must be marked with the following symbols highlighting the switches' capacity to detect every type of current: .

## RCDs technical details

### Type B RCDs

#### Construction features

Type B RCDs consist of one section for the detection of alternating earth fault currents and unidirectional pulsating earth fault currents, which functions independently of the line voltage. For the detection of direct earth fault currents or currents with a minimum residual ripple, type B RCDs have a second electronic section, the functioning of which depends on the line voltage.

The structure of the product is illustrated in the following diagram.

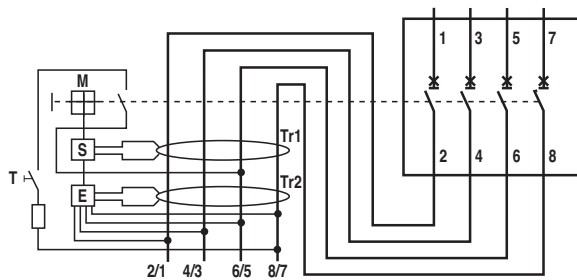



**S** Release

**M** Protection device mechanism

**E** Electronics for the intervention with direct unidirectional earth fault currents

**T** Test device

**Tr1**  Residual current transformer for the detection of sinusoidal earth fault currents

**Tr2**  Residual current transformer for the detection of direct unidirectional currents.

The residual current transformer Tr1 monitors the presence of pulsating and alternating earth fault currents in the electronic installation while residual current transformer Tr2 measures the direct unidirectional currents. In the event of a fault the second transformer transmits the opening command to the release S via the (printed) circuit board E. In type B RCCBs, the section whose functioning depends on the line voltage is supplied by all three-phase conductors and the neutral, so that the functioning as type B is guaranteed even if there is a voltage only in two of the 4 power conductors. In addition, the supply of the electronic section is sized in such a way that the device can safely intervene even if there is a voltage drop of 70%.

In this way an intervention takes place when direct unidirectional earth fault currents emerge, even in the event of faults in the electric power supply grid, for example if there is no neutral conductor.

#### Direct or similar earth fault currents

An increasing amount of industrial equipment is supplied by circuits which in the event of a fault generate direct earth fault currents with a very low residual ripple, which can be even less than 10%. For example with direct current supplied motor drives for pumps, elevators, textile machines etc. it is becoming more common to use inverters with a three-phase rectifier bridge.

In the event of an earth fault current the wave of the earth fault is as indicated in the figure below.

Three-phase rectifier bridge

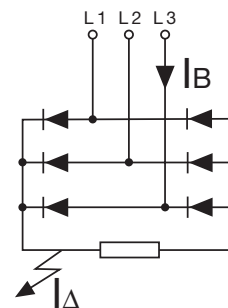

Three-phase wye rectifier

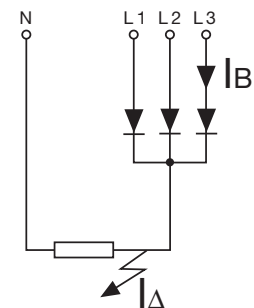

Phase currents

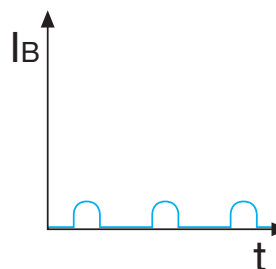

Earth fault current

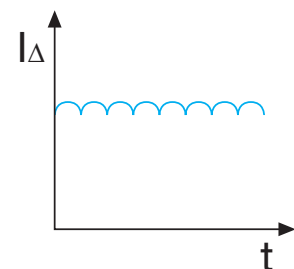

## RCDs technical details

### Type B RCDs

F200 B RCCBs provide additional protection against direct contact and are the right choice to ensure maximum system safety thanks to early detection of fault currents with continuous waveforms or high frequencies.

#### Selection of RCDs. General rules

Type B RCDs are suitable for non-linear circuits that can generate leakages with high direct current (> 6 mA) and/or high frequency components. Such components can be found in several industrial components and applications that embed or depend on electronics.

The main circuits that can be considered responsible for such leakages and the common applications where Type B could be demanded are:

#### Circuits containing single and three-phase rectifiers

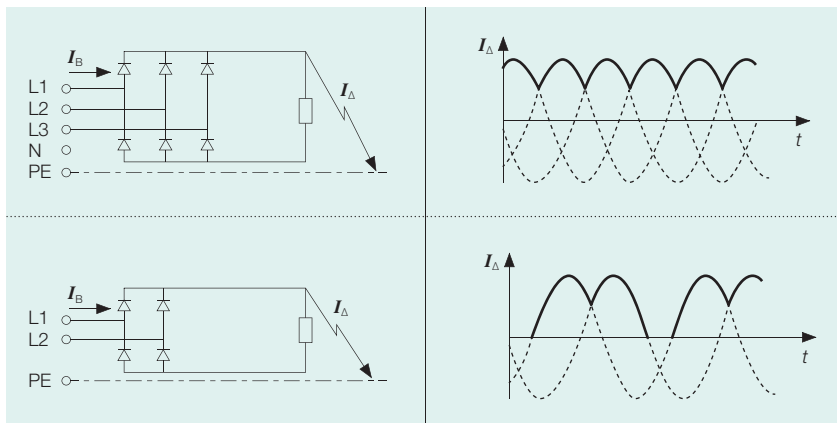

#### Circuits containing rectifiers with high levelling capacity

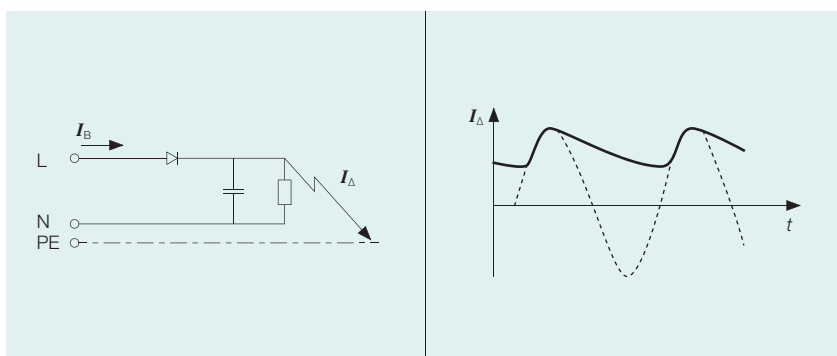

#### Circuits containing rectifiers with active power factor correction

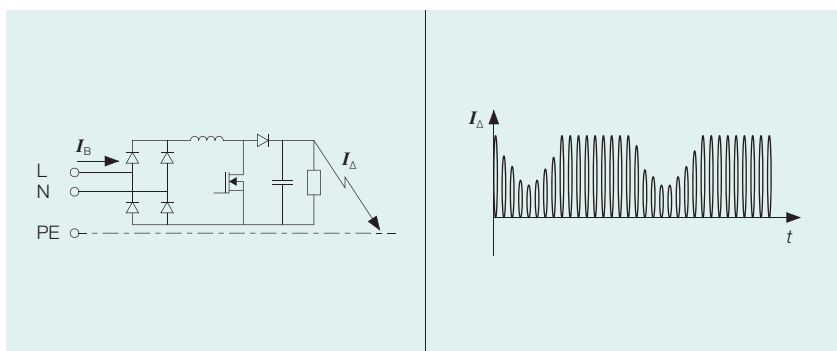

## RCDs technical details

### Type B RCDs

#### Circuits containing continuous voltage generators with no separation from a.c. network

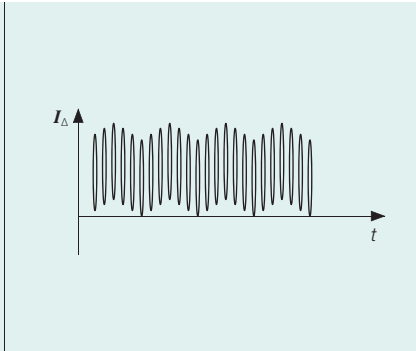
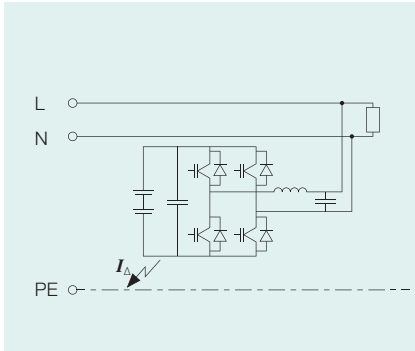

#### Circuits containing continuous voltage generators

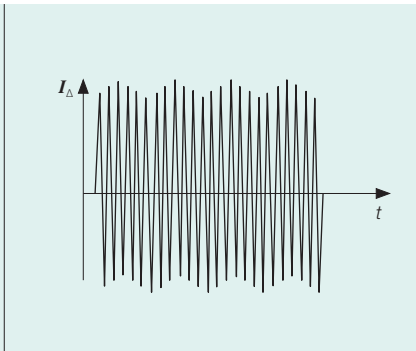
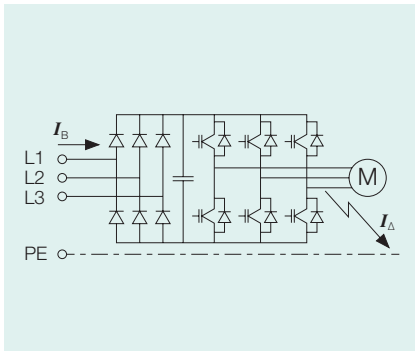









## RCDs technical details

### Type B RCDs

#### Immunity to nuisance tripping: advantages of Type B RCCBs

RCDs Type B are advance-designed products that, on one hand, are able to protect from different kinds of faults, regardless of their waveform; on the other hand, they are immune to unwanted trippings.

In order to be such an effective device in terms of protection, every Type B RCD must withstand successfully all the tests provided by the Standards. In the testplan are foreseen several tripping waveforms that are considered to represent the best approximation to a real fault condition in case of non linear circuits.

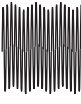
Tripping waveforms for Type B RCDs		
	Residual current form	Limit value of tripping current
Alternating		$0,5...1,0 I_{\Delta n}$
Unidirectional pulsating		$0,35...1,4 I_{\Delta n}$
Unidirectional pulsating with phase angle mode		Cut-off angle $90^\circ$ from $0,25$ to $1,4 I_{\Delta n}$
		Cut-off angle $135^\circ$ from $0,11$ to $1,4 I_{\Delta n}$
Alternating sinusoidal residual current plus pulsating dc current, suddenly applied or smoothly increasing		Max. $1,4 I_{\Delta n} + 0,4 I_{\Delta n}$ d.c.
Unidirectional pulsating superimposed on direct		Max. $1,4 I_{\Delta n} + 0,4 I_{\Delta n}$ d.c.
Multi-frequency		From $0,5$ to $1,4 I_{\Delta n}$
Two-phase rectified		From $0,5$ to $2,0 I_{\Delta n}$
Three-phase rectified		
Direct without ripple		
Alternating up to 1 kHz		Current frequency 150 Hz from $0,5$ to $2,4 I_{\Delta n}$
		Current frequency 400 Hz from $0,5$ to $6 I_{\Delta n}$
		Current frequency 1000 Hz from $0,5$ to $14 I_{\Delta n}$

## RCDs technical details

### Type B RCDs

To prove their immunity to unwanted tripping, Type B residual current devices must successfully pass further severe tests such as:

- 8/20  $\mu$ s impulse up to 3000 A (s. fig. 1);
- 10 ms impulse up to  $10 I_{\Delta n}$  (s. fig. 2).

These tests emulate the conditions that an RCD must withstand in case of overvoltages or leakages due to EMC filters or electronic loads. Type B devices can be considered suitable for all difficult applications, not only in terms of protection, but of operational continuity as well.

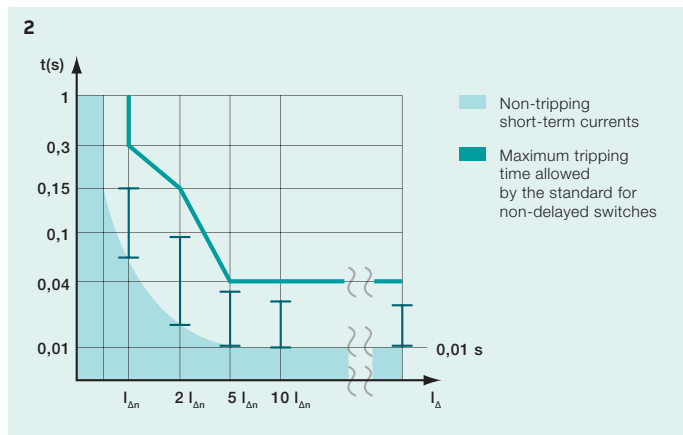
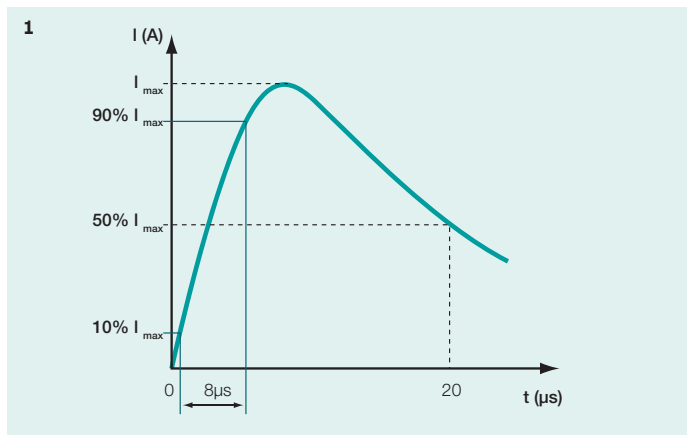

#### Tripping times

Type	Fault currents	Tripping time at			
Standard or short-time delay	Alternating currents	$1 \times I_{\Delta n}$	$2 \times I_{\Delta n}$	$5 \times I_{\Delta n}$	500 A
	Pulsating DC currents	$1,4 \times I_{\Delta n}$	$2 \times 1,4 \times I_{\Delta n}$	$5 \times 1,4 \times I_{\Delta n}$	500 A
	Smooth DC currents	$2 \times I_{\Delta n}$	$2 \times 2 \times I_{\Delta n}$	$5 \times 2 \times I_{\Delta n}$	500 A
Standard or short-time delay		Max. 0,3 s	Max. 0,15 s	Max. 0,04 s	Max. 0,04 s
Selectiv S		0,13 - 0,5 s	0,06 - 0,2 s	0,05 - 0,15 s	0,04 - 0,15 s



# RCDs technical details

## Type B RCDs

### Variation of residual current tripping thresholds according to frequency

#### F200 B 30 mA

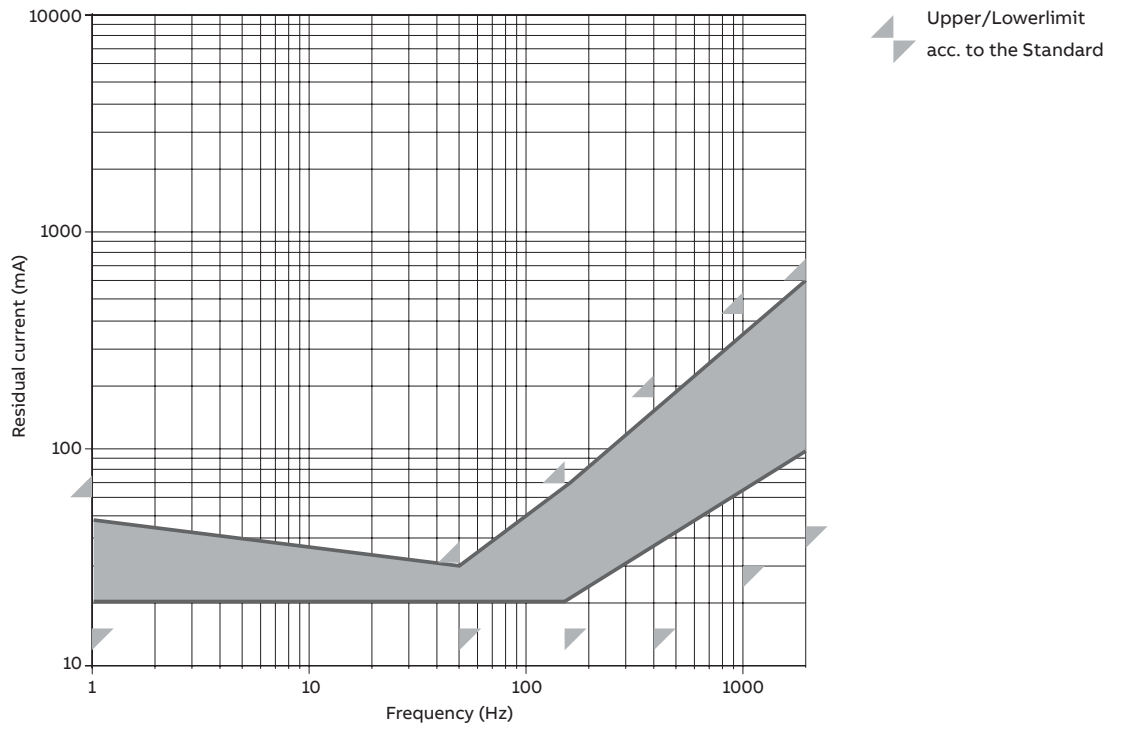

#### F200 B 300 mA

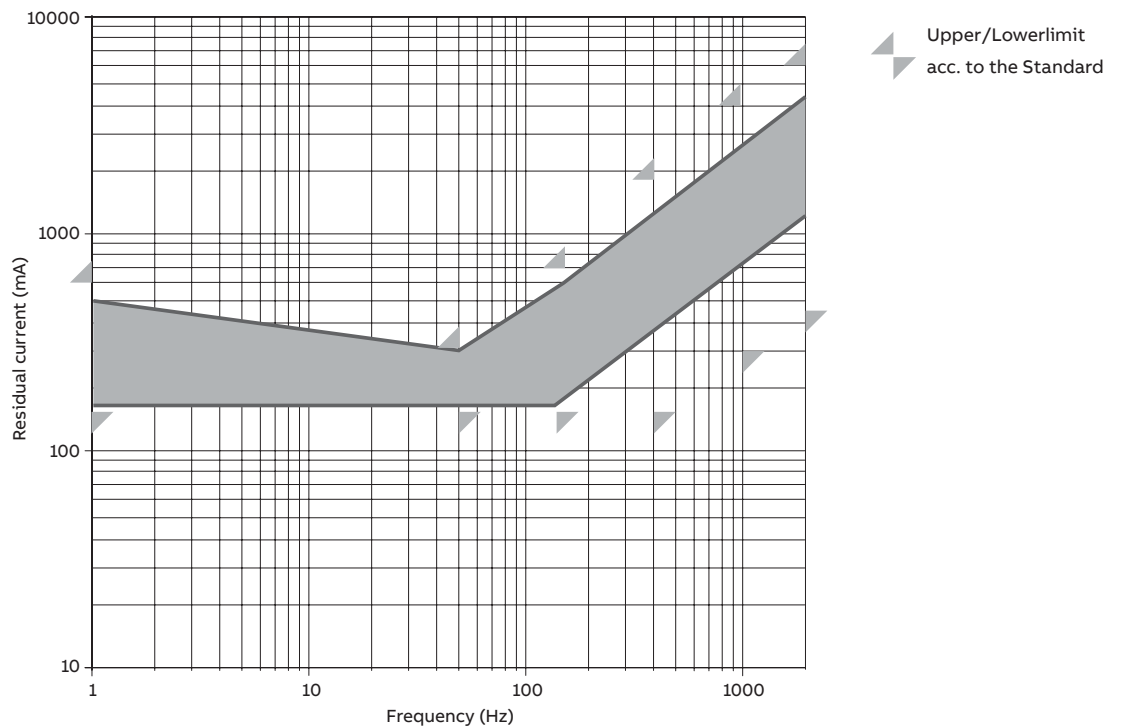

## RCDs technical details

### Type B RCDs

#### F200 B 500 mA

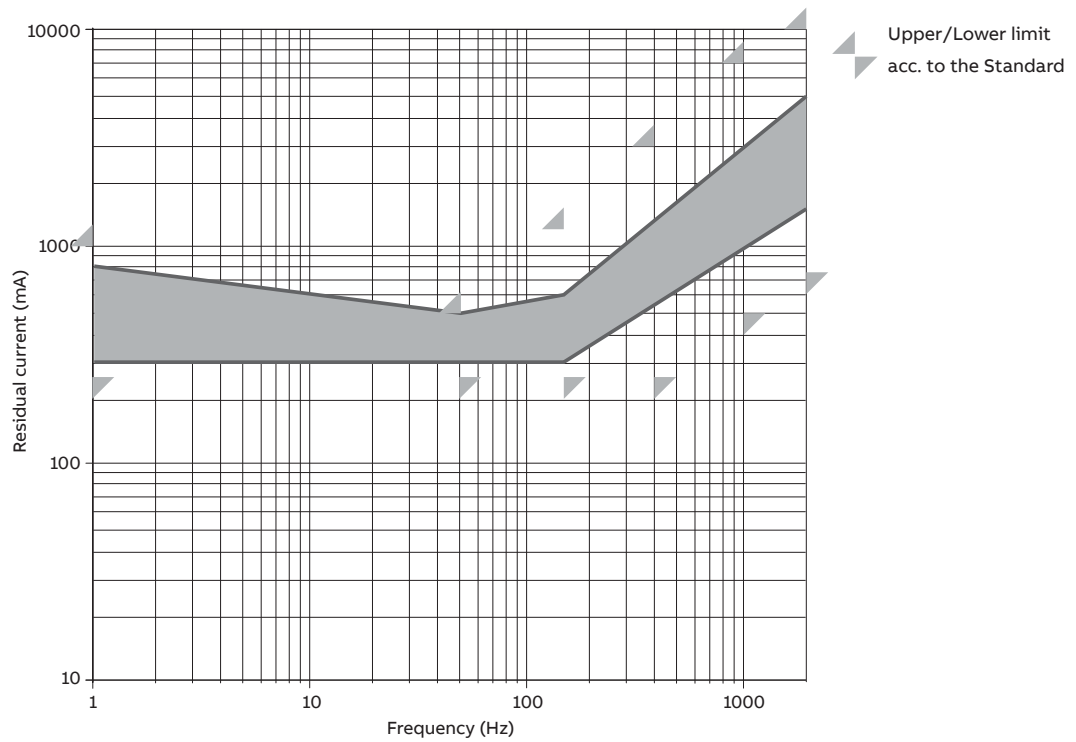



# RCDs technical details

## Type B RCDs

### F200 B high ratings

#### F204 B 30 mA

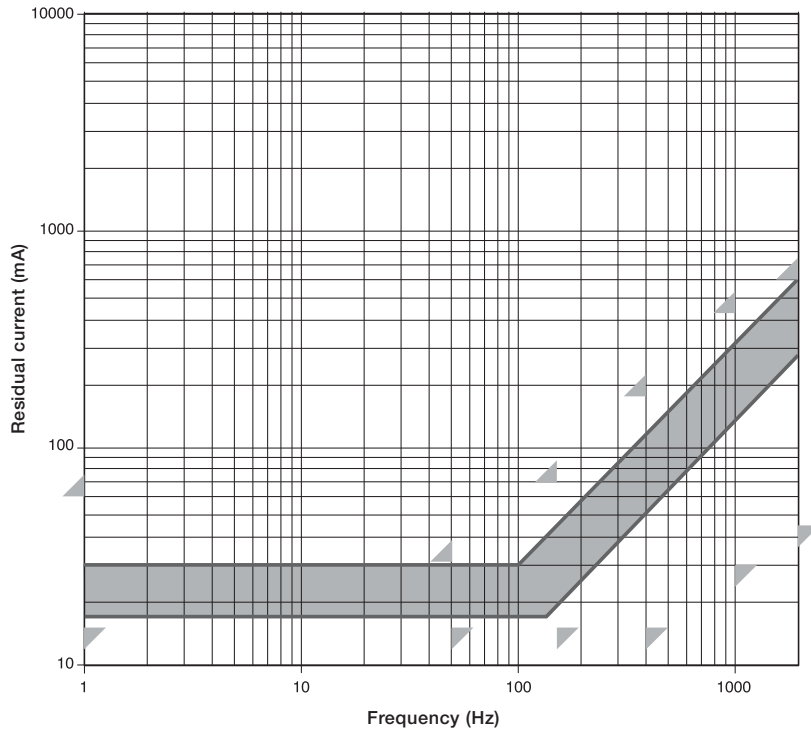

Upper/Lowerlimit acc. to the Standard

#### F204 B 300 mA

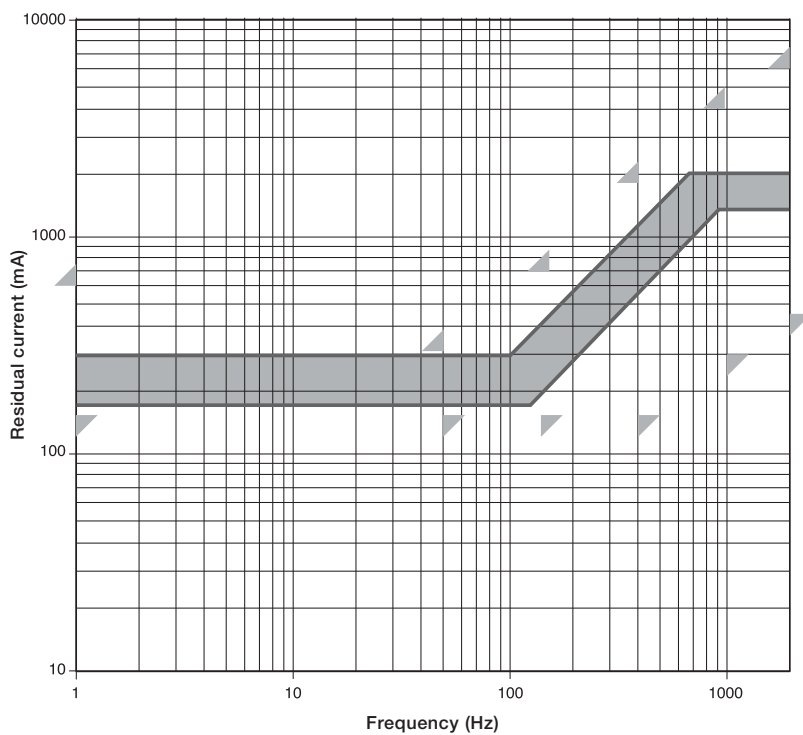

Upper/Lowerlimit acc. to the Standard

## RCDs technical details

### Type B RCDs

#### F204 B 500 mA

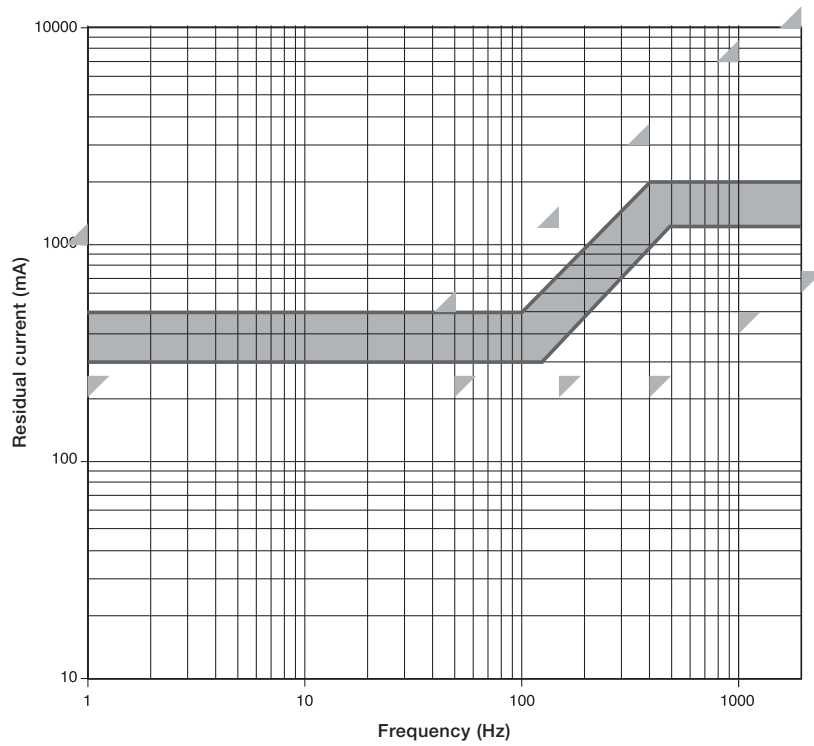

Upper/Lowerlimit  
acc. to the Standard

## RCDs connected in series

This new section is a summary of “Guide to the selection of RCDs connected in series”.

For more details and complete explanation please refer to the white paper with document ID 9AKK108467A1850.

In many installations, two or more RCDs are installed in series: one common upstream RCD protects the distribution circuit and one or more downstream RCDs protect the final circuits. We use the term “in series” for a connection as per figure below, as commonly intended in the installation practice. It remains understood that the

upstream RCD does not necessarily see the same leakage current seen by any one of the downstream RCDs (as the correct, formal definition of “series” would require), for it generally collects the sum of said leakage currents. We believe that this abuse of terminology be for the sake of simplicity and brevity.

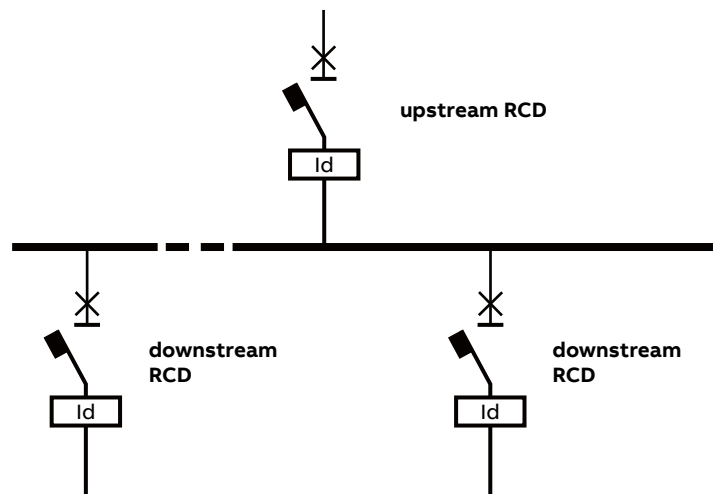

First, the correct types for downstream RCD(s) must be selected, basing on load characteristics.

This implies that the installation must be properly designed, so that protecting RCDs operated within their intrinsic limits. Then, the upstream RCD must be selected accounting for the total DC earth fault expected at the upstream point of installation, when the loads are in faulty and in fault-free conditions.

The following conditions hold:

- If a type B RCD is installed downstream, then the maximum DC earth current let through by it (and reaching the upstream RCD) is  $2 \times I_{\Delta n}$ , because this is the tripping threshold of type B RCDs in case of DC residual current.
- If a type F RCD is installed downstream (and assuming that the installation had been properly designed, so that the type F RCD operated within its limits), then the maximum DC earth current expected through it (and reaching the upstream RCD) is 10 mA regardless of its  $I_{\Delta n}$ , because this is the maximum DC earth fault that type F RCDs may tolerate.
- If a type A RCD is installed downstream (and assuming that the installation had been properly designed, so that the type A RCD operated within its limits), then the

maximum DC earth current expected through it (and reaching the upstream RCD) is 6 mA regardless of its  $I_{\Delta n}$ , because this is the maximum DC earth fault that type A RCDs may tolerate.

- Type AC RCDs are not expected to operate in presence of DC earth currents and therefore (assuming that the installation had been properly designed so that they operated safely) they do not contribute to the DC earth leakage that reaches the upstream RCD.

In case of two or more RCDs of type A/F/B installed in parallel downstream, the maximum DC earth current through the general upstream RCD, in the worst case, is the sum of the earth currents through each of the downstream RCDs. This is clearly a pessimistic scenario: in a real situation, DC components stemming from different subcircuits may not be simultaneously present (e.g., EV charging stations not necessarily operating at the same time), or the DC earth current from several parallel loads may at least partially compensate each other. Anyway, over long periods of time the likelihood of particularly unfavorable conditions rises, and the installation must be conservatively designed so to be on the safe side.

## RCDs connected in series

It is therefore essential to ensure that RCDs installed upstream of one or more RCDs of type A, F or B are not blinded by an excessive DC earth current through them. Particularly, the RCD installed upstream must always provide protection in the event of an AC fault in the system portion under its surveillance.

Some supplied loads like, e.g., electric vehicle charging, are expected to cause a non-negligible DC earth current component, also in fault free conditions. If such DC earth current

component is large enough to impair the correct operation of the upstream RCD, the latter may fail to protect, e.g., a superimposed AC earth fault, as illustrated in Figure below.

Typical example of installation where an upstream RCD of type AC/A/F (i.e., less-than-B) may be blinded by an excessive DC earth current let through by a downstream RCD of type B. If not properly selected, the upstream RCD may not operate correctly, therefore failing to clear a superimposed AC fault.

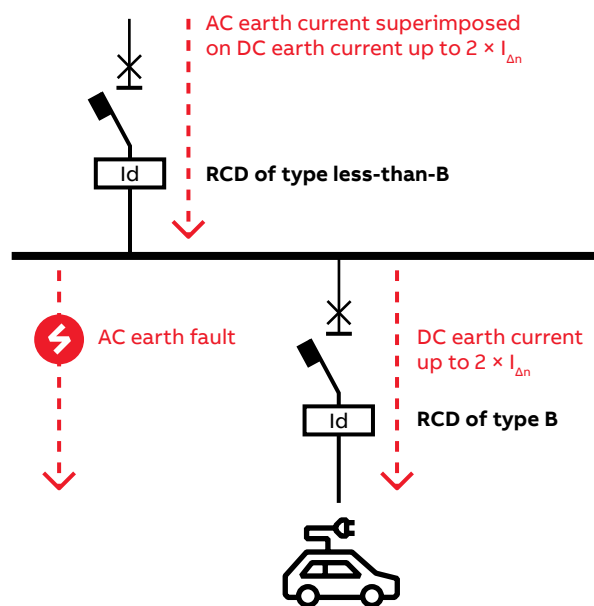

For the sake of simplicity, only a two-level installation will be dealt with, considering a single RCD upstream and one or more RCDs downstream. The general, multi-level case, which may also present a different number of levels in different portions, can be addressed similarly, starting from the low-

est levels, then suitably selecting the RCDs of the levels immediately above, and then moving to the levels above until the top-most RCD. Anyway, two-level installations are way more common, the multi-level case being reserved to rare exceptions.

## RCDs connected in series

### The simplest solution: type B upstream

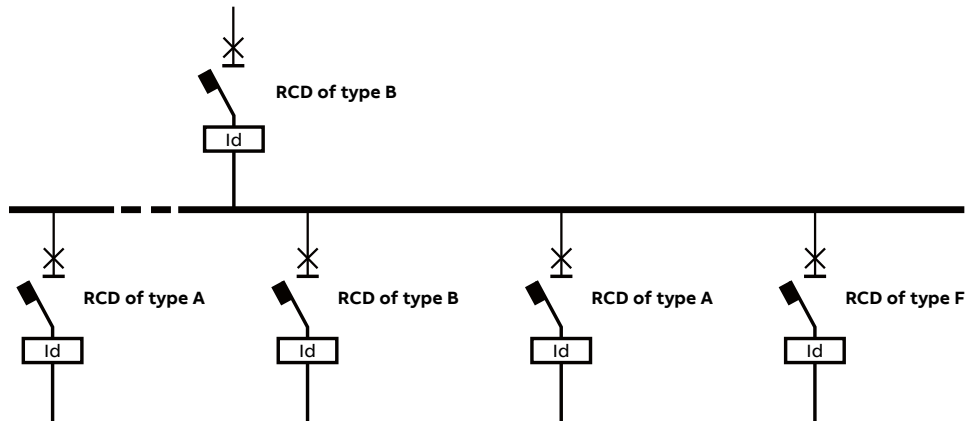

### Alternative solution with ABB RCDs

In the following tables, selective RCDs (denoted by S) are also considered. Such RCDs are characterized by an intentional delay before tripping (non-actuating time), to guarantee that downstream RCDs tripped before the upstream one, i.e., selectivity.

Time delayed industrial type ABB residual circuit breakers, including those with a separate toroid (MRCD), as per Annex B or Annex M of IEC 60947-2 [4], are equivalent to selective RCDs, and are thus included in relevant cases, if the non-actuating time is  $\geq 0.06$  s.

### Important warning.

IEC 60364-5-53:2019/AMD1:2020 [1] is an international standard: in some countries, national standards may be more restrictive and, for instance, may not allow the second option. Therefore, installation engineers must always refer to applicable national rules for the correct selection of RCDs.

## RCDs connected in series

### Installations with type B RCDs downstream

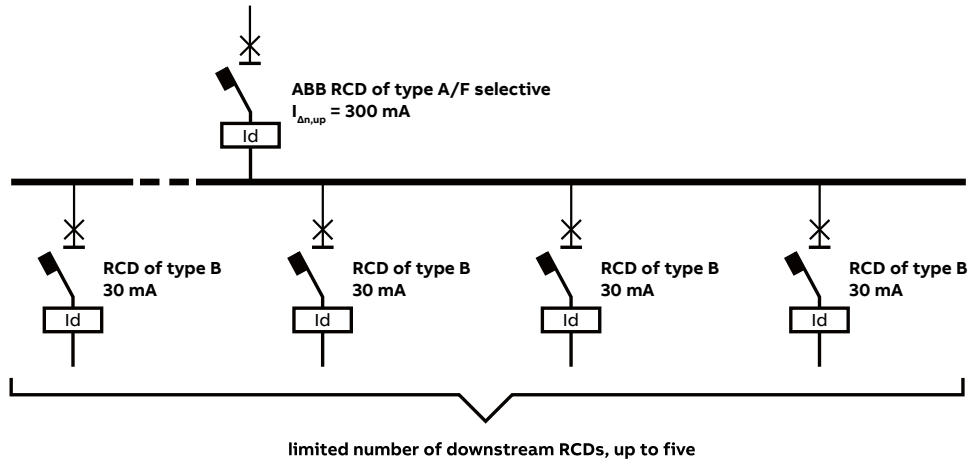

### Installations without type B RCDs downstream

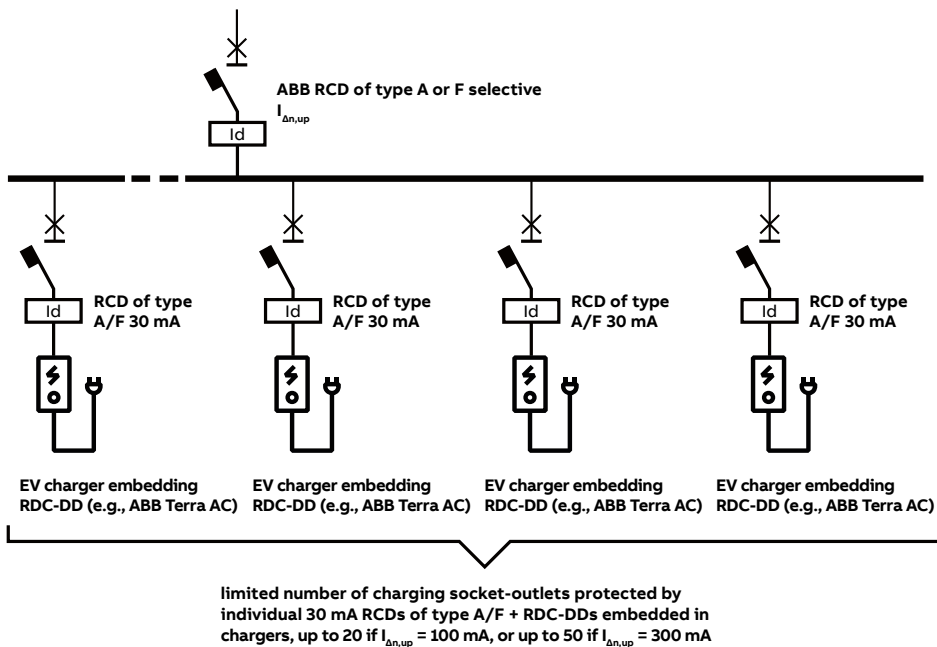

## RCDs connected in series

### Selection of upstream RCD type, allowed when using B type ABB RCDs downstream

case	Downstream RCD					Upstream RCD			
	type	Poles	Rated Current	I $\Delta$ n	Max q.ty	Type	Poles	Rated current	I $\Delta$ n
1	B	2P and 4P	any	30 mA	1	F200 A type	4P	up to 63 A	100 mA
						F200 A type	2P	80-100 A	100 mA
						F200 A type	4P	80-100 A	100 mA
						DDA200 A type	3P/4P	up to 63 A	100 mA
						DS201 AP-R or F type	1P+N	up to 40 A	100 mA
2	B	2P and 4P	any	30 mA	2	F200 A type	2P	up to 63 A	300 mA
						F200 A type	4P	up to 63 A	300 mA
						F200 A type	2P	80-100 A	300 mA
						F200 A type	4P	80-100 A	300 mA
						DDA200 A type	2P	up to 63 A	300 mA
						DS201 A or AP-R or F type	1P+N	up to 40 A	300 mA
						F200 A type Selective	2P	up to 63 A	100 mA
						F200 A type Selective	4P	up to 63 A	100 mA
						F200 A type Selective	2P	80-100 A	100 mA
						F200 A type Selective	4P	80-100 A	100 mA
						DDA200 A type Selective	2P	63 A	100 mA
						DDA200 A type Selective	3P/4P	63 A	100 mA
3	B	2P and 4P	any	30 mA	5	F200 A type Selective	2P	up to 63 A	300 mA
						F200 A type Selective	4P	up to 63 A	300 mA
						F200 A type Selective	2P	80-100 A	300 mA
						F200 A type Selective	4P	80-100 A	300 mA
						DDA200 A type Selective	2P	63 A	300 mA

Please refer to your national standards for any restrictions in series connection of B type RCDs downstream

## RCDs connected in series

### Selection of upstream RCD type, allowed when using without B type ABB RCDs downstream

case	Downstream RCD					Upstream RCD			
	type	Poles	Rated Current	I $\Delta$ n	Max q.ty	Type	Poles	Rated current	I $\Delta$ n
4	"A or (F + charger embedding RDC-DD, e.g., ABB Terra AC)"	2P and 4P	any	30 mA	10	F200 A type	4P	up to 63 A	100 mA
						F200 A type	2P	80-100 A	100 mA
						F200 A type	4P	80-100 A	100 mA
						DDA200 A type	3P/4P	up to 63 A	100 mA
						DS201 AP-R or F type	1P+N	up to 40 A	100 mA
5	"A or (F + charger embedding RDC-DD, e.g., ABB Terra AC)"	2P and 4P	any	30 mA	20	F200 A type	2P	up to 63 A	300 mA
						F200 A type	4P	up to 63 A	300 mA
						F200 A type	2P	80-100 A	300 mA
						F200 A type	4P	80-100 A	300 mA
						DDA200 A type	2P	up to 63 A	300 mA
						DS201 A or AP-R or F type	1P+N	up to 40 A	300 mA
						F200 A type Selective	2P	up to 63 A	100 mA
						F200 A type Selective	4P	up to 63 A	100 mA
						F200 A type Selective	2P	80-100 A	100 mA
						F200 A type Selective	4P	80-100 A	100 mA
						DDA200 A type Selective	2P	63 A	100 mA
DDA200 A type Selective	3P/4P	63 A	100 mA						
6	"A or (F + charger embedding RDC-DD, e.g., ABB Terra AC)"	2P and 4P	any	30 mA	50	F200 A type Selective	2P	up to 63 A	300 mA
						F200 A type Selective	4P	up to 63 A	300 mA
						F200 A type Selective	2P	80-100 A	300 mA
						F200 A type Selective	4P	80-100 A	300 mA
						DDA200 A type Selective	2P	63 A	300 mA

## RCDs technical details

### Use of 4P RCCBs in 3-phase system without neutral pole

#### Use of a 4P RCCB in a 3-phase circuit without neutral

The test button circuit of these RCCBs 4P F 200, regardless of the rating, is wired inside the device between terminal 5/6 and 7/8/N as indicated below, and has been sized for an operating voltage between 110V (170V for the 30mA version according to EN standard) and 254 V (110 and 277 V according to UL 1053).

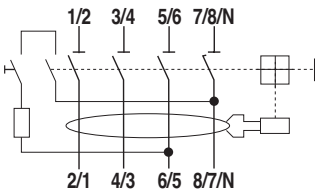

In case of installation in a 3 phase circuit without neutral, if the concatenate voltage is between 110V (170V for the 30mA version according to EN standard) and 254 V (277 V according to UL 1053) for the correct working of the test button there are two possible solutions:

- 1) To connect the 3 phases to the terminals 3/4 5/6 7/8/N and the terminals 4/3 6/5 8/7/N (supply and load side respectively)
- 2) To connect the 3 phases normally (supply to terminals 1/2 3/4 5/6 and load to terminals 2/1 4/3 6/5) and to bridge terminal 1/2 and 7/8/N in order to bring to the terminal 7/8/N the potential of the first phase. In this way the test button is supplied with the phases' concatenate voltage.

If the circuit is supplied with a concatenate voltage higher than 254 V, as in the typical case of 3 phase net with concatenate voltage of 400 V - or 480 V according to UL 1053 - (and voltage between phase and neutral of 230 V or 277 V according to UL 1053), it is not possible to use these connections because the circuit of the test button will be supplied at 400 V and could be damaged by this voltage.

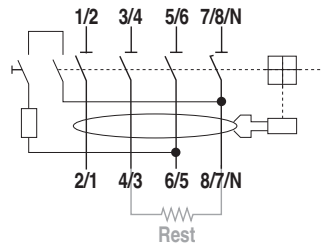

$I_{\Delta n}$ [A]	Rest [ $\Omega$ ]
0.03	2200*
0.03	3900
0.1	2200
0.3	2200
0.5	2200

\* Only for IEC range and 125 A right-sided ratings

In order to allow the correct operation of the test button also in 3 phase nets at 400 V - 480 V according to UL 1053 - (concatenate voltage) it is necessary to connect normally the phases (supply to terminals 1/2 3/4 5/6 and load to terminals 2/1 4/3 6/5) and to bridge terminal 4/3 and 8/7/N by mean of an electric resistance as indicated above.

In this way the test button circuit is fed at 400 V - 480 V according to UL 1053 - but for example in an IEC compliant RCCB with  $I_{\Delta n}=0.03$  A there will be the  $Rest=3.3$  kOhm resistance in series to the test circuit resistance. Rest will cause a voltage drop that leaves in the test circuit a voltage less than 254 V - 277 V according to UL 1053. Rest resistance must have a power loss higher than 4 W.

In the normal operation of the RCCB (test circuit opened) the Rest resistance is not fed so it does not cause any power loss.

#### The solution RCCBs with neutral pole on left side

The test button circuit of these RCCBs is wired inside the device between terminal 3/4 and 5/6 as indicated below, and it has been sized for an operating voltage between 195 V and 440 V - 480 V. In case of a three phase system without neutral with concatenate voltage between phases of 230 V or 400 V - 277 V or 480 V - it is enough to connect the 3 phases normally (supply to terminals 1/2 3/4 5/6 and load to terminals 2/1 4/3 6/5) without any bridge.

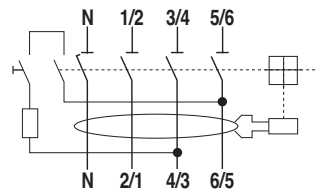

## RCDs technical details

### Operating voltage of test button

#### Operating voltage of test button

The operation of RCDs depends on the maximum and minimum operating voltage of the test button.



This symbol represents the circuit of test button

#### Maximum and minimum operating voltage of DS201 test button

DS201  
 Ut = 110-264 V;  
 for 30mA: Ut = 170-264V

DS201 M 110V  
 Ut = 110-264V

DS301C  
 for 30mA; Ut = 170-264 V

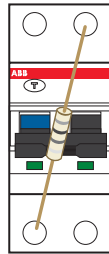
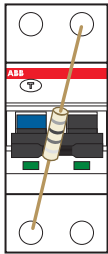

Between the two terminals there is a rated voltage of 110-264 V

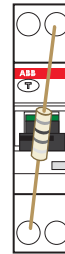

#### Maximum and minimum operating voltage of DS 200 and DDA 200 test button

DDA 202 and DS 202  
 In = 25-40 A  
 Ut = 110 - 254 V;  
 for 30mA: Ut = 170-254V

DDA 203 and DS 203  
 In = 25-40 A  
 Ut = 195 - 440 V;  
 for 30mA: Ut = 300-440V

DDA 204 and DS 204  
 In = 25-40 A  
 Ut = 195 - 440 V;  
 for 30mA: Ut = 300-440V

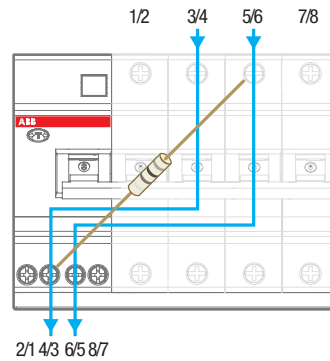
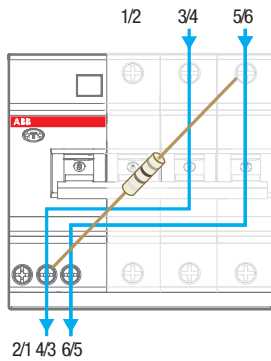
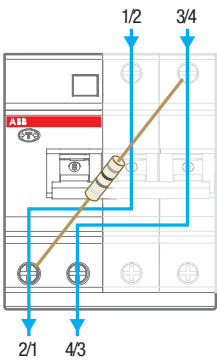

DDA 202 and DS 202  
 In = 63 A  
 Ut = 110 - 254 V;  
 for 30mA: Ut = 170-254V

DDA 203 and DS 203  
 In = 63 A  
 Ut = 195 - 440 V;  
 for 30mA: Ut = 300-440V

DDA 204 and DS 204  
 In = 63 A  
 Ut = 195 - 440 V;  
 for 30mA: Ut = 300-440V

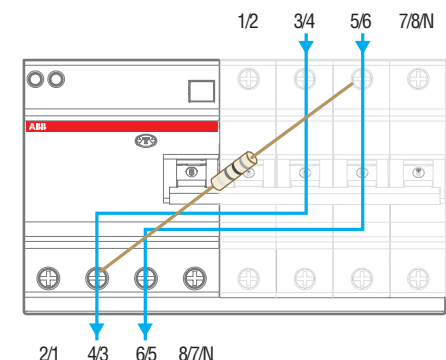
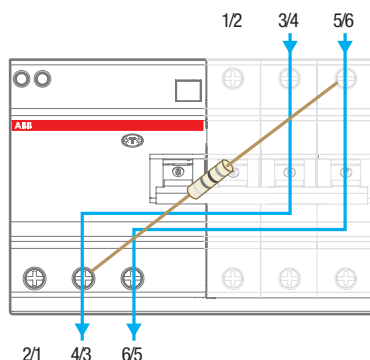
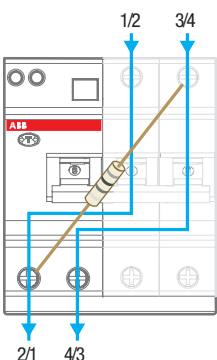

## RCDs technical details

### Operating voltage of test button

#### Maximum and minimum operating voltage of DDA 200, special version 110 V

DDA 202 110 V  
 In = 25-40-63 A  
 Ut = 110-254 V

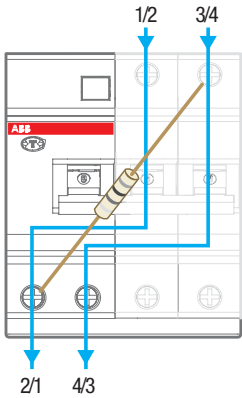

DDA 203 110 V  
 In = 40 A  
 Ut = 110-254 V

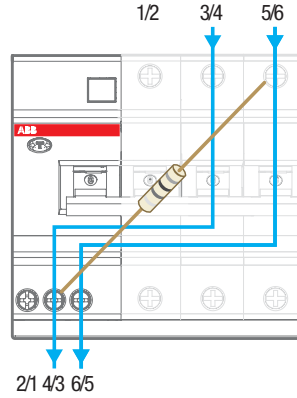

DDA 203 110 V  
 In = 63 A  
 Ut = 110-254 V

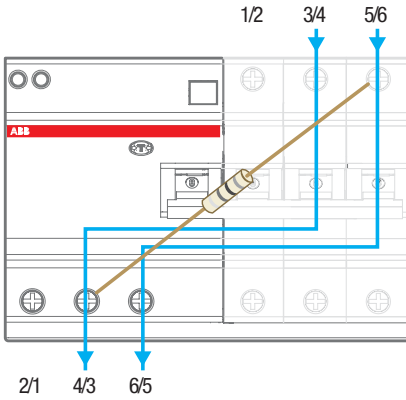

DDA 204 110 V  
 In = 63 A  
 Ut = 110-254 V

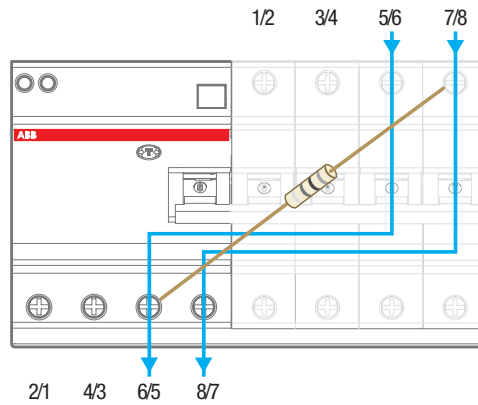

#### Maximum and minimum operating voltage of the DS203NC

DS203NC  
 Ut= 195-440V (300-440V for 30 mA)

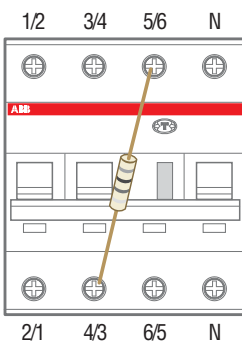

## RCDs technical details

### Operating voltage of test button

#### Maximum and minimum operating voltage of DDA 200, special version 400 V

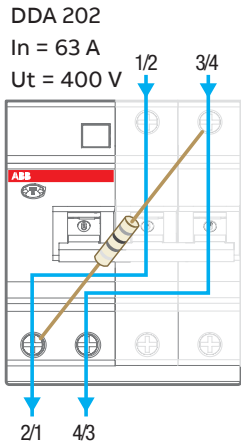

#### Maximum and minimum operating voltage of DDA 200 B type test button

DDA 202 B  
 $I_n = 63\text{ A}$   
 $U_t = 195\text{-}254\text{ V}$  (170-254 V for 30 mA)

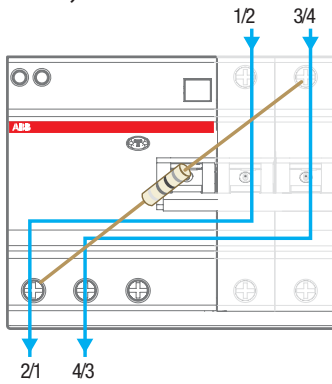

DDA 203 B  
 $I_n = 63\text{ A}$   
 $U_t = 310\text{-}440\text{ V}$  (300-440 V for 30 mA)

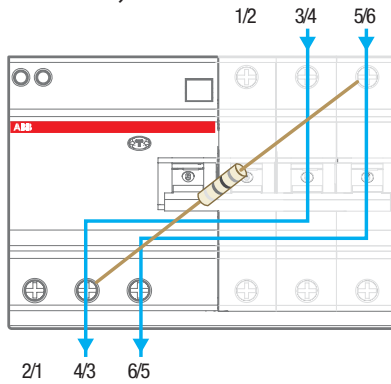

DDA 204 B  
 $I_n = 63\text{ A}$   
 $U_t = 195\text{-}254\text{ V}$  (300-440 V for 30 mA)

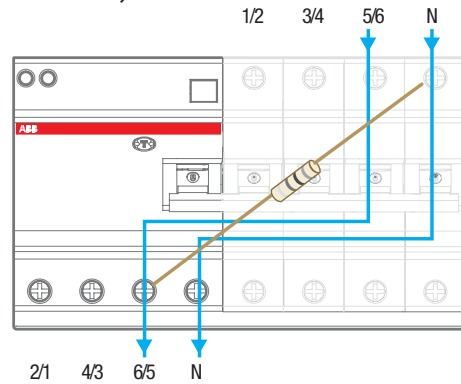

#### Maximum and minimum operating voltage of DDA 200 AE test button

DDA 202 AE  
 $I_n = 63\text{ A}$   
 $U_t = 184\text{-}264\text{ V}$

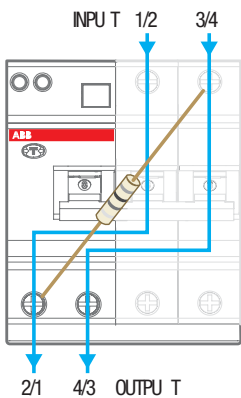

DDA 203 AE  
 $I_n = 63\text{ A}$   
 $U_t = 310\text{-}440\text{ V}$

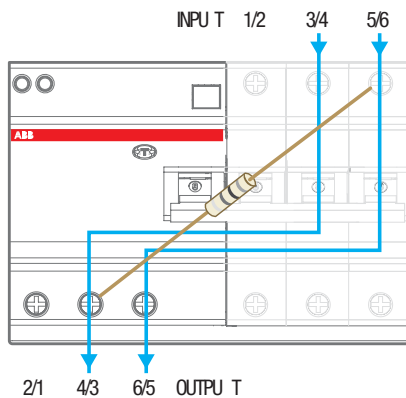

DDA 204 AE  
 $I_n = 63\text{ A}$   
 $U_t = 184\text{-}264\text{ V}$

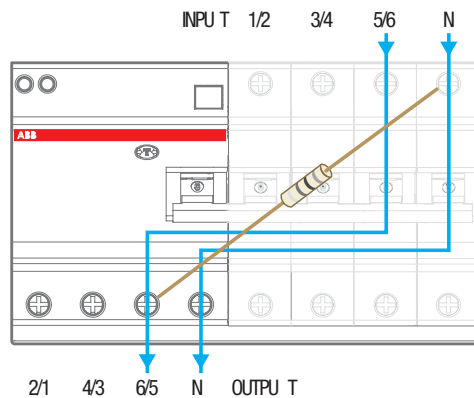

## RCDs technical details

### Operating voltage of test button

#### Maximum and minimum operating voltage of F 200 test button

F 202  
 $I_n \leq 100 \text{ A}$   
 $U_t = 110 - 254 \text{ V};$   
 for  $30\text{mA}^{\text{①}}$ :  $U_t = 170 - 254 \text{ V}$   
 1/2 3/4

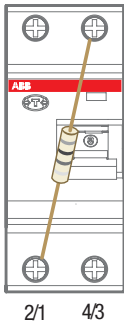

F 204 neutral on right  
 $I_n \leq 100 \text{ A}$   
 $U_t = 110 - 254 \text{ V};$   
 for  $30\text{mA}^{\text{①}}$ :  $U_t = 170 - 254 \text{ V}$   
 1/2 3/4 5/6 7/8/N

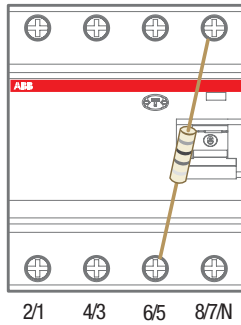

F 204 neutral on left  
 $I_n \leq 100 \text{ A}$   
 $U_t = 195 - 440 \text{ V};$  for  $30\text{mA}$ :  $U_t = 250 - 440 \text{ V}$

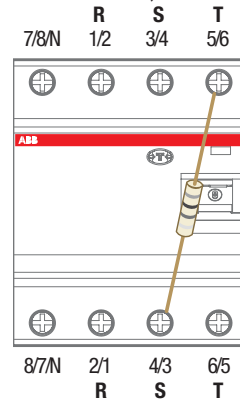

For use in 3-phases circuit without neutral at 400 V it is possible to connect the three phases R, S and T like in the figure.

F 204 neutral on right  
 $I_n = 125 \text{ A}$   
 $U_t = 185 - 440 \text{ V};$   
 for  $30\text{mA}^{\text{①}}$ :  $U_t = 150 - 250 \text{ V}$   
 1/2 3/4 5/6 7/8/N

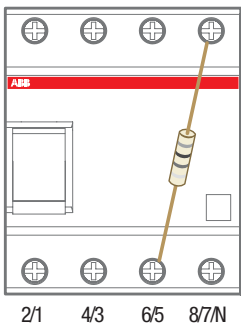

2 CSC 000436F 0202

① Only for versions with marking according to EN 61008-1; EN 61008-2-1

F 204 neutral on left  
 $I_n = 125 \text{ A}$   
 $U_t = 185 - 440 \text{ V}$   
 for  $30\text{mA}$ :  $U_t = 250 - 440 \text{ V}$   
 7/8/N 1/2 3/4 5/6

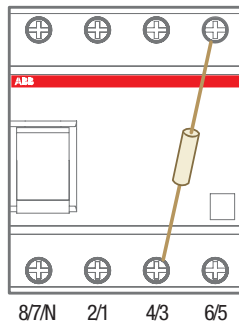

F202 110V  
 $I_n \leq 100 \text{ A}$   
 $U_t = 110 - 254 \text{ V}$

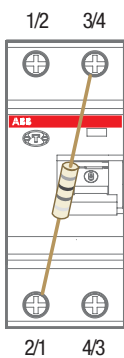

F 204 110V  
 $I_n \leq 100 \text{ A}$   
 $U_t = 110 - 254 \text{ V}$

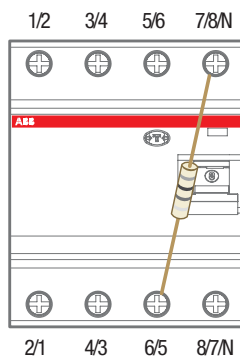

## RCDs technical details

### Operating voltage of test button

#### Maximum and minimum operating voltage of DDA 800 and DS800 test button

DDA 802  
DS802  
 $I_N \leq 125 \text{ A}$   
 $U_t = 195\text{-}690 \text{ V}$

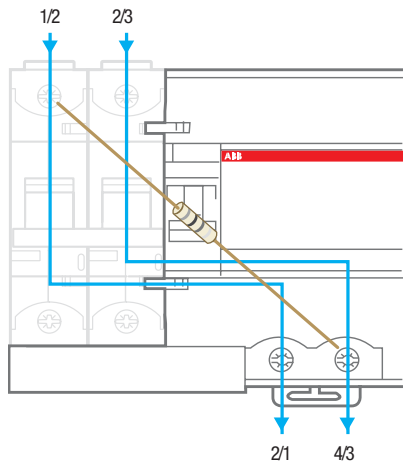

DDA 803  
DS803  
 $I_N \leq 125 \text{ A}$   
 $U_t = 195\text{-}690 \text{ V}$

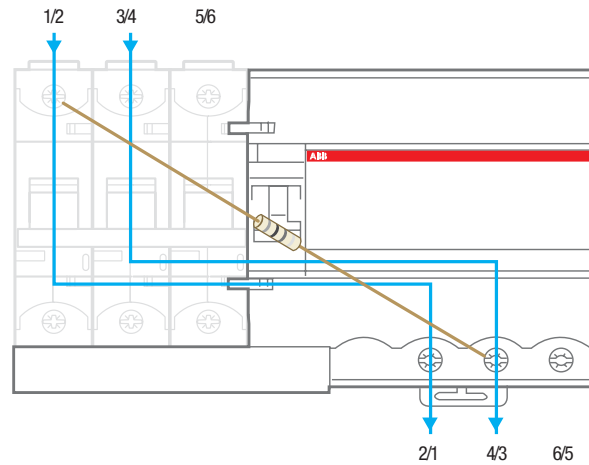

DDA 804  
DS804  
 $I_N \leq 125 \text{ A}$   
 $U_t = 195\text{-}690 \text{ V}$

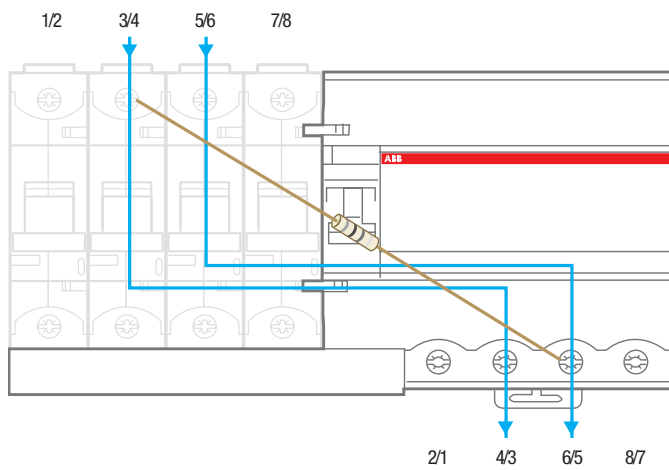

## RCDs technical details

### RD2 residual current relays

#### RD2 residual current monitors

They operate combined with appropriate toroidal transformers (in 9 different diameters).

The relay can command the tripping of the protection circuit-breaker release, thus opening the circuit.

According to the IEC 62020 Standard, these relays are “A Type”. They are sensitive to leakage sinusoidal currents and to leakage pulsating currents with direct components. Thus they can be defined as “A type”.

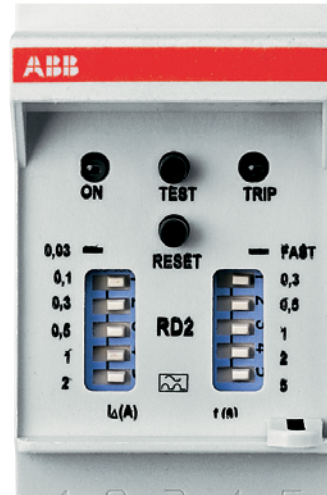

#### More technical characteristics

<b>Calibration tolerances</b>		- sensitivity	75% ± 10%
		- time	75% ± 10%
<b>Power consumption</b>	[W]		0.45 at 48 V AC/DC
			1.2 at 110 V AC/DC
			3.4 at 230 V AC
			11 at 400 V AC
<b>Dielectric test voltage at ind. freq. for 1 min.</b>	[kV]		2.5
<b>Max. peak current with 8/20 μs wave</b>	[A]		5000
<b>Installation position</b>			any
<b>Protection degree</b>			IP20

## RCDs technical details

### RD3 residual current relays

#### RD3 electronic residual current relay

RD3 is a residual current device that in combination with a toroidal transformer is able to detect and evaluate earth fault current. If used in combination with a shunt-trip or undervoltage release, it can realize the opening of a circuit breaker ensuring earth leakage current protection.

RD3



RD3M



RD3P



#### Setting of residual operating current and trip time delay.

Using the rotary selectors on the front of the device, it is possible to adjust the residual operating current and the trip time delay.

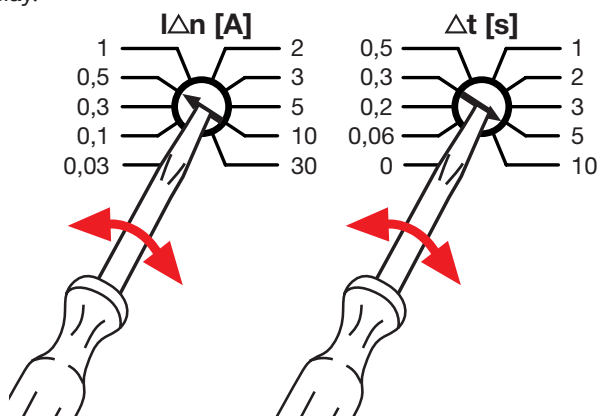

Adjustment of residual operating current ( $I_{\Delta n}$  [A]) and trip time delay ( $\Delta t$  [s]).

#### Main features

	Pre-alarm	Autoreset	Fail-safe
RD3	Placing the dip-switch in the ON position enables the pre-alarm function: the output contact on terminals 7 8 9 will change state in the event of a residual current exceeding 60% $I_{\Delta n}$ .	Placing the dip-switch in the ON position enables the automatic Reset function: the Relay OUTPUT contacts revert to their original state once the fault condition ceases.	Built into the device (positive safety). In case of absence of supply to the device RD3 the output contact on terminals 10 11 12 will change state as shown in the figures.
RD3M	■		■
RD3P	■	■	■

## RCDs technical details

### RD3 residual current relays

#### Indicators

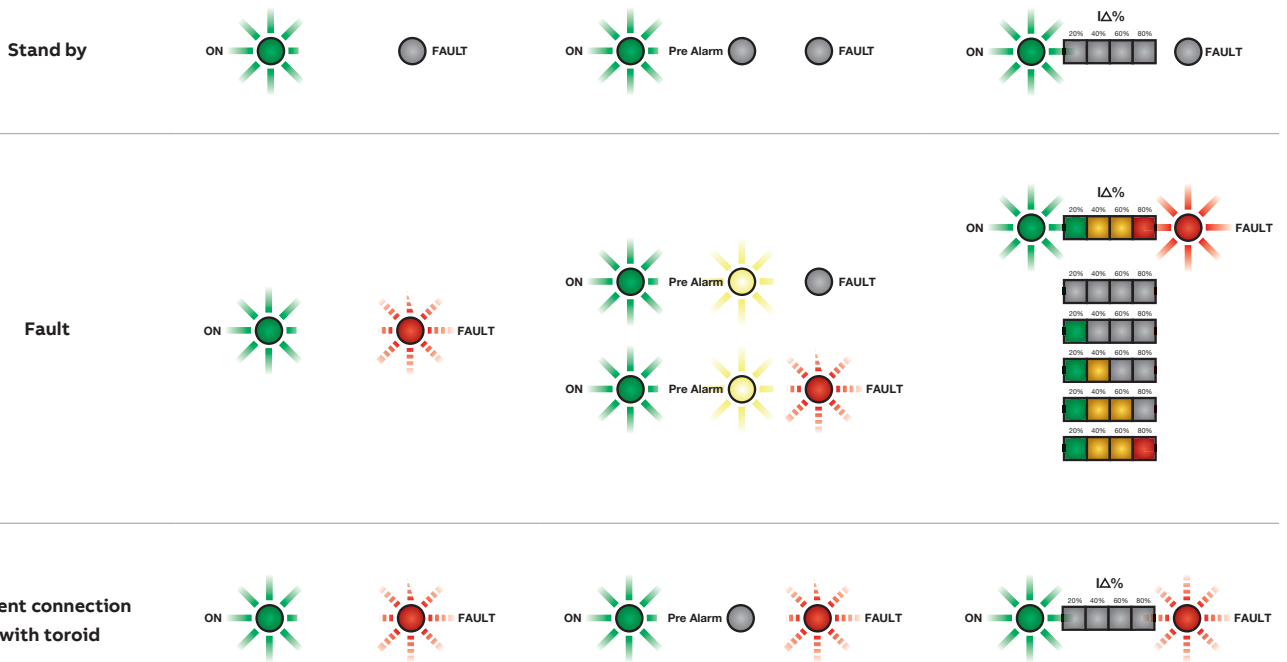

#### Fail-safe - RD3, RD3M, RD3P

Integrated in the device (positive safety). In case of power supply voltage failure of RD3 device, the output contacts numbered 10 11 12 will switch as shown below.

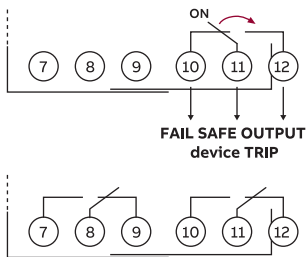

Contacts when the device is OFF

#### Pre-alarm - RD3P, RD3M

When the dip-switch is set to ON, the prealarm function is activated: the output contact marked by the 7 8 9 terminals will switch in case of a fault detected by the device exceeding 60%  $\Delta$ .

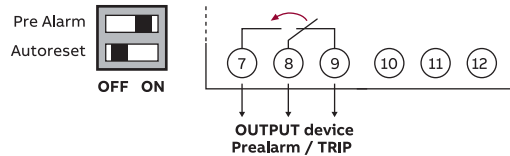

#### Autoreset - RD3P

When the dip-switch is set to ON, the automatic Reset function is activated: the output device contact will return to stand-by when the fault condition has been resolved.

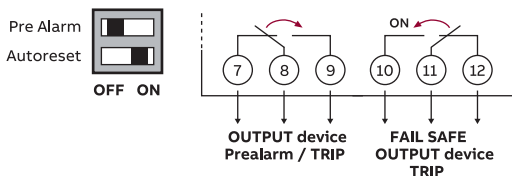

## RCDs technical details

### RD3 residual current relays

#### Test

To perform the relay test, press the button on the front. The relay can be reset via the front button or a remote button, as shown in the figure:

#### Test

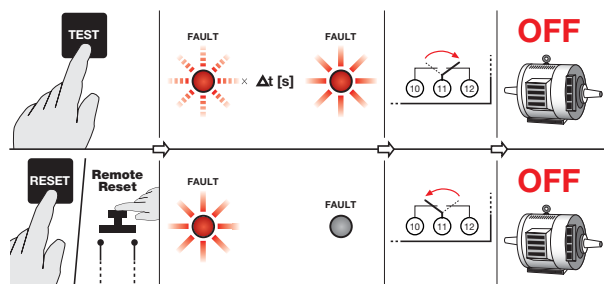

On RD3P version, a no trip test can also be performed by simultaneously pressing the front test and reset buttons for 3 seconds. In this case, the output contacts will not switch, as shown in the figure below:

#### Test NO TRIP - RD3P

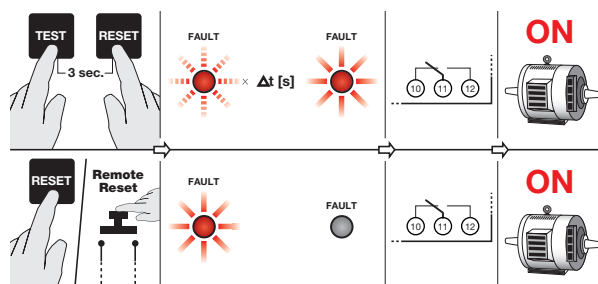

#### Associated circuit breakers (and relative releasers)

- Tmax range from T1 to T5, In up to 630 A, Ue up to 690 V, with UVR undervoltage release or SOR shunt opening release
- XT range from XT1 to XT4, In up to 250 A, Ue up to 690 V, with UVR undervoltage release or SOR shunt opening release
- pro M Compact S200 range with In up to 63 A, Ue up to 440 V, with S 2C-A shunt trip or S 2C-UA undervoltage release

Tripping time (RD3 output relay switching time), cumulative time (with associate circuit breakers), non-trip time limit:

#### RD3: tripping time. cumulative time. non intervention time

Time selection	IΔn		2 IΔn		5 IΔn		10 IΔn	
	tripping time	cumulative time with associate circuit breaker	tripping time	cumulative time with associate circuit breaker	tripping time	cumulative time with associate circuit breaker	tripping time	cumulative time with associate circuit breaker
Dt [s]	≤ [s]	≤ [s]	≤ [s]	≤ [s]	≤ [s]	≤ [s]	≤ [s]	≤ [s]
0	0.2	0.3	0.12	0.15	0.02	0.04	0.02	0.04
0.06	0.3	0.5	0.17	0.2	0.09	0.15	0.09	0.15
0.2	0.45	0.5	0.45	0.5	0.45	0.5	0.45	0.5
0.3	0.55	0.6	0.55	0.6	0.55	0.6	0.55	0.6
0.5	0.6	0.6	0.6	0.6	0.6	0.6	0.6	0.6
1	1.2	-	1.2	-	1.2	-	1.2	-
2	2.2	-	2.2	-	2.2	-	2.2	-
3	3.2	-	3.2	-	3.2	-	3.2	-
5	5.2	-	5.2	-	5.2	-	5.2	-
10	10.2	-	10.2	-	10.2	-	10.2	-

## RCDs technical details

### ELR front panel residual current relays

#### ELR: tripping time, cumulative time, non intervention time

Time selection $\Delta t$ [s]	$I\Delta n$		$2 I\Delta n$		$5 I\Delta n$		$10 I\Delta n$		
	tripping time $\leq$ [s]	cumulative time with associate circuit breaker $\leq$ [s]	non-intervention time [s]	tripping time $\leq$ [s]	cumulative time with associate circuit breaker $\leq$ [s]	tripping time $\leq$ [s]	cumulative time with associate circuit breaker $\leq$ [s]	tripping time $\leq$ [s]	cumulative time with associate circuit breaker $\leq$ [s]
0	0.04	0.3	-	0.025	0.15	0.02	0.04	0.02	0.04
0.06	0.1	0.5	0.06	0.08	0.2	0.08	0.15	0.08	0.15
0.2	0.16 +15%	-	0.2	0.15 +15%	-	0.15 +15%	-	0.15 +15%	-
0.3	0.3 +15%	-	0.3	0.3 +15%	-	0.3 +15%	-	0.3 +15%	-
0.5	0.5 +15%	-	0.5	0.5 +15%	-	0.5 +15%	-	0.5 +15%	-
1	1 +15%	-	1	1 +15%	-	1 +15%	-	1 +15%	-
2	2 +15%	-	2	2 +15%	-	2 +15%	-	2 +15%	-
3	3 +15%	-	3	3 +15%	-	3 +15%	-	3 +15%	-
5	5 +15%	-	5	5 +15%	-	5 +15%	-	5 +15%	-

## RCDs technical details

### Toroidal transformers

#### Toroidal transformers

The choice of toroidal transformers is made according to the useful diameter and the minimum value of the leakage current to be detected.

#### Technical features of the toroidal transformers

Type	Toroid useful diameter [mm]	Max rated current [A] <sup>(1)</sup>	Min measurable current [mA]	Maximum capacity [A]
TRM	29	65	30	160
TR1	35	75	30	250
TR2	60	85	30	400
TR3	80	160	100	800
TR4	110	250	100	1250
TR4/A	110	250	300	1250
TR160	160	400	300	2000
TR160/A	160	400	500	2000
TR5	210	630	300	3200
TR5/A	210	630	500	3200
TR6	300	630	500	5000
TR6/A	300	630	1000	5000

(1) Toroidal transformers selection for use with ELR/RD3 according to IEC/ EN 60947-2 Annex M in combination with MCBs S200 range and MCCBs Tmax range up to T5 (630 A) and XT range up to XT4 (250 A)

## RCDs technical details

### Toroidal transformers

#### Technical characteristics

		TRM	TR1	TR2	TR3	TR4	TR4A	TR160	TR160A	TR5	TR5A	TR6	TR6A
Core		closed	closed	closed	closed	closed	open	closed	open	closed	open	closed	open
Available internal diameter	[mm]	29	35	60	80	110	110	160	160	210	210	300	300
Weight	[kg]	0.17	0.22	0.28	0.45	0.52	0.6	1.35	1.6	1.45	1.85	2.1	2.3
Minimum measurable current	[mA]	30	30	30	100	100	300	300	500	300	500	500	1000
Installation position		Any											
Operating temperature	[°C]	-10...+70											
Storage temperature	[°C]	-20...+80											
Transformation ratio		500/1											
Dielectric test voltage at industrial freq. for 1 min.	[kV]	2.5											
Max. insulating voltage	[V a.c.]	1000											
Max. thermal overload	[kA]	40/1 sec.											
Connections		Screw terminal boards, max. section 2.5 mm <sup>2</sup>											
Protection degree		IP20											

#### Generality

They must be mounted with residual current monitors upstream the lines or loads to be protected; all active conductors (phases and neutral) of single-phase as well as of three-phases lines must pass through them.

In this way these devices perform the vector sum of line currents detecting the possible homopolar differential currents that leak to earth: their core of sheet iron has high magnetic properties that allow to detect even very low leakage currents.

The choice of a toroidal transformer depends on the conductor or on the bar to be used.

It is suggested to use the open versions in case of revamping or upgrading of an existing installation.

#### Installation

All active conductors can be introduced in the toroidal transformers without the need of respecting any specific sense of introduction (P1-P2 or P2-P1). The output signal

must be picked up from terminals 1 (S1) and 2 (S2) and connected to the residual current monitor, while terminals 3 and 4 must be connected to the test output of those relays of FPP range with this function. With RD2 they must remain disconnected. For this connection it is better to use twisted or shielded cables, possibly far from busbars. The minimum recommended section of connection cables should have a maximum resistance of 3 Ω; anyway consider a maximum length of connection of 20 m for 0.5 mm<sup>2</sup> and of 100 m for 2.5 mm<sup>2</sup>.

For versions with openable core it is necessary to control that the contact surface of the two semi-cores is clean, that bolts are tight and that connection cables connections on both sides are intact.

Connection cables with metallic shielding or armor must be earthed downstream the toroidal transformer; if they run within the transformer they must be earthed in the opposite direction.